



Norges Geologiske
Undersökelse

Nr. 162

SILVER DEPOSITS
AT KONGSBERG

(THE MINERAL ASSEMBLAGE OF A NATIVE
SILVER - COBALT - NICKEL ORE TYPE)

BY

HENRICH NEUMANN

WITH 8 PLATES AND 40 FIGURES
IN THE TEXT



OSLO 1944

I KOMMISJON HOS H. ASCHEHOUG & CO.

NORGES GEOLOGISKE UNDERSØKELSE NR. 162

SILVER DEPOSITS AT KONGSBERG

(THE MINERAL ASSEMBLAGE OF A NATIVE
SILVER - COBALT - NICKEL ORE TYPE)

BY
HENRICH NEUMANN

WITH 8 PLATES AND 40 FIGURES
IN THE TEXT

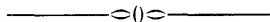

OSLO 1944
I KOMMISJON HOS H. ASCHEHOUG & CO.

Contents.

	Page		Page
Abstracts	5	Mineral b	64
History.....	6	Galena	64
Geology of the area	10	Stephanite	65
Banded gneisses and dioritic gneisses	13	Polybasite (- pearceite)	67
Vinor amphibolites	14	Pyrrargyrite - proustite	68
Red granitic gneiss	14	Pyrite	70
The diabase dykes of the Oslo area	15	Marcasite	71
The fahlbands	15	Arsenopyrite	73
The veins	17	Diarsenides of Ni and Co, ram- meisbergite - safflorite and chloantite - smaltite	74
The sulphide-bearing quartz- breccia veins	17	Chlorargyrite	79
Calcite veins	21	Fluorite	79
Main veins	22	Quartz	80
The calcite - nickel - cobalt - arsenide - native silver veins	22	Anatase	81
The origin of the veins and the physical conditions attend- ing their formation	31	Calcite	82
The minerals	34	Barite	86
Native silver	37	Erythrite	88
Arsenic	53	Epidote	88
Dyscrasite	54	Axinite	89
Argentite and acanthite	55	Prehnite	96
Jalpaite	57	Asbestos	96
Sphalerite	57	Apophyllite	97
Chalcopyrite	60	Chlorite. Green ooze	97
Tetrahedrite - tennantite	61	Armenite	99
Niccolite	62	Hyalophane	102
Pyrrhotite	63	Albite	105
Minerals of the sternbergite group	64	Datolite	106
		Natrolite	107
		Laumontite	107
		Stellerite	108
		Harmotome	113

	Page		Page
Coal blend. (Anthracite, mineral coal)	114	The calcite - zeolite paragenesis	121
Paragenetic relations ..	117	Supergene ores and minerals .	122
The quartz - coal blend - fluorite - axinite - pyrite paragenesis	117	Comparison with other occurrences of the native silver-cobalt-nickel ore type	123
The calcite - barite - fluorite - sulphide - silver - Ni - Co - arsenide paragenesis	118	Acknowledgements	128
		Literature	129

Abstracts. The described deposits of the native silver - nickel - cobalt - arsenide type are found in a pre-cambrian series of rocks, by far the greater part of which is made up of banded, dioritic and granitic gneisses (Map p. 12).

The described minerals have been deposited in narrow veins which are striking more or less E—W and are found to constitute a system of "Fiederspaltten". The pressure under which the minerals have been deposited must be classed about 1000 atm., and the temperature has probably varied from about 4—500° C to about 200° C (p. 33).

Calcite is predominating in the veins. Sulphite is uncommonly rare. On p. 35 and p. 36 will be found graphic illustrations showing the relative quantities of the chief minerals.

The various minerals have been described. The lamini-form crystals of native silver (p. 45) might be of special interest. Special interest also attaches to the curious way in which marcasite occurs, i. e. as primarily deposited mineral older than silver (p. 73). Marcasite must have been deposited under a comparatively high temperature from neutral or basic solutions. This is not in concordance with what is usually found, and it does not agree with the experimental dates. — Anatase (p. 81) and datolite (p. 106) have not up till now been known from Kongsberg. This also applies to stellerite, which is a rather rare zeolite (p. 113). Stellerite is the pure Ca-component of the stilbite series. — Armenite (p. 99), a new mineral from these deposits, has earlier been described by me (45). This mineral has the formula $\text{BaCa}_2[\text{Al}_2\text{Si}_8\text{O}_{10}]_8\text{H}_2\text{O}$.

The minerals appear in three parageneses: The oldest one is a quartz - coal blend - fluorite - axinite - pyrite paragenesis. Younger is a calcite - barite - fluorite - sulphide - native silver - Ni-Co-arsenide paragenesis. These three parageneses are usually rather intimately connected with each other.

A comparison with other ore deposits of this kind offers so many strikingly corresponding paragenetic features that it will justify the working out of a general map showing the paragenesis of deposits of the native silver - cobalt - nickel - ore type (p. 126).

History.

In the summer of the year 1623 native silver was found in Sandsvær, and operating was subsequently started by the government at the present locality of the mine Kongens grube (His Majesty's Mine). According to tradition the find was made by a boy shepherd, Jacob Christoffersen Grosvold.

his historical investigations arrived at the

R. Støren, Min. ing.,¹ has according to conclusion that the occurrences of silver at Sandsvær must have been known at a considerably earlier date. At all events reliable evidence is available to the effect that one of them, the mine Kessel, has been worked at a period previous to the foundation of the Kongsberg Silver Works. It strikes one

that the region around Kongsberg, i. e. Telemark, Numedal and Sandsvær, is the home of the national trade of silver smithing. The conclusion offers itself that this trade, particularly the making of trinkets, which of a considerable age in this country, is closely connected with the occurrences of silver, which made the material for this trade easily available to the population of these districts. We ought to bear in mind that native silver from Kongsberg is so pure that it needs no refining. Smelting under the cover of charcoal in the smith's forge is quite sufficient.

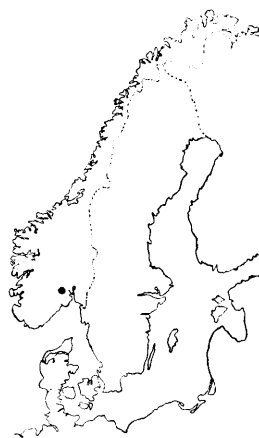

Fig. 1. Key map showing location of Kongsberg.

¹ This section is on the whole an extract from an unpublished paper by R. Støren, bearing the title: „Notes on the Kongsberg Silver Works.“ (Notiser angående Kongsberg Sølvverk.)

However, the peasants had to carry on this mining in secrecy or the crown must be expected to appropriate the occurrences, in which case the peasants would lose the advantages of their illegal mining at a small scale. Now, it could not be avoided that the authorities got some suspicion as to the real state of affairs, and they did their utmost to get information about the occurrences. The administrators of justice therefore used to take the opportunity, whenever any one from among the peasants had been found guilty of any serious crime, of offering mercy and acquittance in return for information about the localities of the find places of ore. Now it appears that the father of the above mentioned boy shepherd, his name was Christoffer Loftstuen, had in the year 1614 had the bad luck of killing a man, what in those days would rather often happen if one of the antagonists in a quarrel was of a hot temperament. On account of this he had been fined 50 riksdaler, a sum which corresponds to the value of about 50 £ to-day. This was a very large sum of money to be demanded from a peasant in the 17th century. In 1622 the money had still not been paid. It is possible that he has tried to pay the fine in native silver, which he has smelted in the smith's forge, and in this way he has perhaps awakened the suspicion of the authorities. The next year he has confessed his knowledge of the occurrence, or rather he has arranged the discovery of the ore occurrence by his son, in order to get out of his difficulties. On the 21st of December in the same year, Christian IV issued a proclamation announcing heavy punishments for secret mining for silver and also for sale of the product which is to be regarded as stolen goods. Subsequently to this it appears that several peasants appeared before the authorities, promising to point out finding places of silver ore as soon as the snow had disappeared. This shows that the silver ore occurrences in question must have been known by the inhabitants of the region beforehand.

During the 320 years which have passed since the first official find of silver ore was made, the Kongsberg Silver Works have, most of the time under government management, produced about 1270 tons of pure silver from about 130 larger and smaller mines. The gross quantity of silver in the ores amounts to about

2000 tons. The difference is due to loss during the metallurgical processes, and also to the fact that in former days rather large quantities of silver were stolen. The average production during this large period has been 4 tons a year, varying from $\frac{1}{3}$ of a ton to 15,7 tons a year. The last 50 years have shown an average production of about 8 tons a year.

The largest depth has been reached in the oldest mine, Kongens grube (His majesty's Mine), the bottom of which is 1076 meters below level.

The history of the Kongsberg Silver Works comprises such a long period that it is quite natural that the works have been subject to very varying circumstances due to war-time disturbances, pestilence and market fluctuations, and still more to the great variations in the contents of ore in the veins. Elsewhere in this paper is found a discussion of the difficulties in finding any definite rules for the deposition of native silver in the veins; such would supply useful directions for the mining itself. Several times in the history of the Silver Works has occurred the unpleasant situation of dwindling contents of silver in the mines, the managers being quite unable to decide where to turn in order to find ore. In such situations pessimistic miners have been only too inclined to put forth the supposition of the mines having been emptied and thus no ore being left. Miners must always take into account the possibility of the dwindling of the occurrences or the possibility of the ores becoming less rich towards larger depths, and in the case of the Kongsberg occurrences, dark periods in the history of the Silver Works have often caused miners to believe that these processes were at hand, particularly so as long as it had not been sufficiently proved that the occurrences *might* hold against larger depths.

Instructive in this respect is the history of Kongens grube. The silver ore had dwindled and there had taken place a change in the character of the veins when they had been worked for three years (1624—1627), after which the mine was abandoned. In 1630 mining was again started at the same place, and ore was found at 16 m level, whereupon mining was carried on until the mine was again abandoned at 26 m level in 1676. In 1686 mining was again resumed in the same mine, which was now

worked with varying success. In 1725 the ore gradually took off and the vein dwindled at 160 m level, but all the same, work was carried on and in 1749 rather rich ore was found at 260 m level. From 1793 are preserved records of work being carried on at 328 m level without fit ore being found, the mine being still worked on expectations, but in the year 1798 the mine was again abandoned, it was believed never to be worked again. In spite of this, work was again resumed and in 1827 mining was carried on below the bottom of the mine Kongens grube itself, where rich ore was found and the mining was carried on quite well down to approximately 500 m level (1856), where the ore again began to dwindle. In the eighteeneighties, rich openings were made at about 600 m level and ore was found until in the beginning of the present century a level of about 840 m had been reached. Then came a rather poor period until at 912 m level ore of varying richness was found on which mining was carried on to about 1000 m level. Here the veins start dwindling, and only sporadically they carry silver down to 1067 m level. At this level the working of this mine was abandoned at the end of the nineteenthirties owing to the great depth. The lowest regions of this mine are now filled with water.

Thus no less than 6 or 7 times the silver ore in the mine Kongens grube has to all appearance gone out, but nevertheless it is a fact that suitable silver ore has in the mine been found and produced from more than 1000 m level.

The last decades have again proved a very dark period to the Kongsberg Silver Works. The accounts have sometimes shown large deficits. To some extent this crisis may be due to the same causes as the earlier ones, but an additional and very serious factor is the continued and heavy decrease of the price of silver in the course of the last 70 years. This decrease is partly due to international trade conditions, but it must also to some extent be ascribed to the increase in the production of silver as a bi-product of the process of gaining other metals from their ores, when these ores do also contain small quantities of silver.

In order to prevent the calamity which would be represented by the closing down of the Kongsberg Silver Works, a calamity

both to the district in which the works are situated and to the country at large, the Kongsberg Silver Works have made for alteration in the methods and an extension of its field of production. This is done partly by a further treatment of the silver so as to produce compounds (AgNO_3) and certain alloys partly by an extension of the capacity of the smelting house so as to reduce ores which are not found in the mines of the Kongsberg Silver Works, and also by the production of various other articles such as garnet and materials for macadam.

Besides investigations are at present being made as to the possibility of mining for other ores found in this district.

Geology of the Area.

The geology of the area has been described by Carl Bugge (12) and Arne Bugge (6, 7, 8, 9, 10, 11) in a series of publications, which will provide more explicit information. Here I am just going to give a short survey which might be of some importance to the study of the silver occurrences in question. What follows is chiefly a condensed extract from the works of C. Bugge and A. Bugge, who, however, I ought to remark, maintain that most of the rocks mentioned below are true eruptives, a conception which I cannot share.

The mines are situated in what is called the pre-Cambrian Kongsberg—Bamble formation. To the west this formation is cut off from the supra crustals and the gneisses of the pre-Cambrian Telemark formation by the great South-Norwegian friction-breccia. To the east it borders on Cambro-Silurian sediments and on the Permian alkaline rocks of the Oslo-area. (Fig. 2.)

The rocks of the Kongsberg formation are here given according to age: 1) Banded gneisses and dioritic gneisses (grey Kongsberg gneiss), 2) Vinor amphibolites, and 3) granitic gneiss (Kongsberg granite). Finally the formation is cut through by diabase dykes striking E—W originating from the Oslo area close by to the east. These diabase dykes in all probability belong to the Permian age.

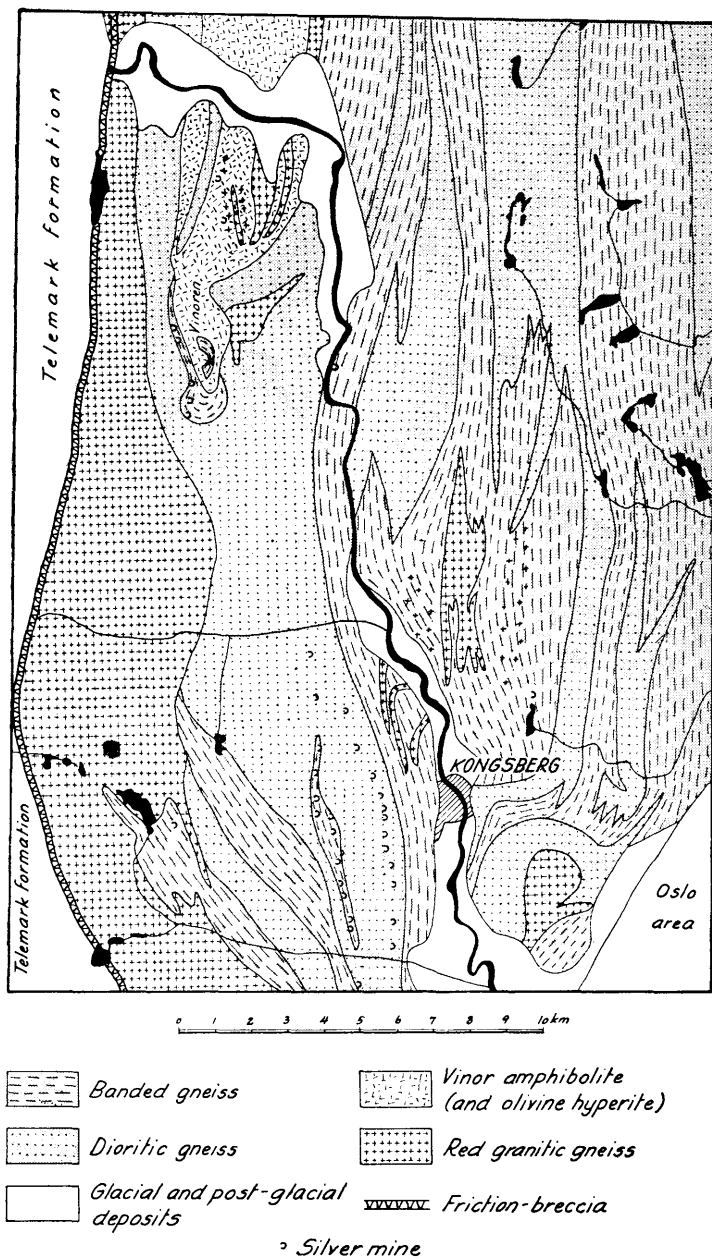

Fig. 3. Geologic map of Kongsberg mining district. Reconstructed after A. Bugge and C. Bugge.

		Geological process	Product
Permian (and later?)	After-activity of the alkaline rock series in the Oslo area.	Hydrothermal and Last eruption in the Oslo area.	Calcite veins with cobalt-nickel-arsenides and native silver.
			Diabase dykes Quarz veins with pyrite, chalcopyrite, galena and sphalerite.
Precambrian		Granitisation	Red granitic gneiss. Hyperites are altered to Vinor amphibolites.
		Period of eruption	Olivine hyperites (and other gabbros?) in dykes and massives.
		Dioritisation and metamorphic differentiation	Banded and dioritic gneisses.
	Supra crustal rocks		

Table 1. The geological processes of the Kongsberg area and their products.

Banded Gneisses and Dioritic Gneisses.

These gneisses have been formed by a dioritizing of an older complex of rocks, which has been completely changed, so as to render it very hard to venture any definite statement as to its original character. In the Knuten formation, which has been described by C. Bugge (12), the rocks belonging to this category have probably been less changed than elsewhere. In this formation a considerable amount of staurolite is found. This fact, seen in connection with the fact that in other parts of the Kongsberg—Bamble formation large quantities of sillimanite is found, might imply that the original series of rocks to a large extent has consisted of supra crustal rocks.

The banded gneisses consist of incessantly alternating bands of dioritic and amphibolitic structure. The thickness of the bands

varies from a few centimeters to 30—40 meters and more. In some places dark bands predominate. In other places we find light bands. The banded gneiss must have been formed through a metamorphic differentiation. Where the dioritisation has been very thoroughgoing the result is long and heavy S—N striking sweeps of dioritic gneiss without any dark bands. There are evidences to the effect that this dioritic gneiss has in some places been melted and has erupted as a true abyssic diorite.

Vinor Amphibolites.

The amphibolites appear in long dykes, the striking directions of which vary from NW to NE. They also appear in massives of varying size. At Vinoren to the north of Kongsberg there is a more extensive massive that has given the name to the amphibolite. In the interior of the massives fresh and original olivine-hyperite is found, and with great confidence it can be concluded that these amphibolites are transformations of original hyperites, or at all events of original gabbroid rocks.

Red Granitic Gneiss.

This gneiss has been formed by granitisation of all the original rocks. C. Bugge (12, p. 81) as an outline drawing which very distinctly shows the front of granitisation. Fig. 4.

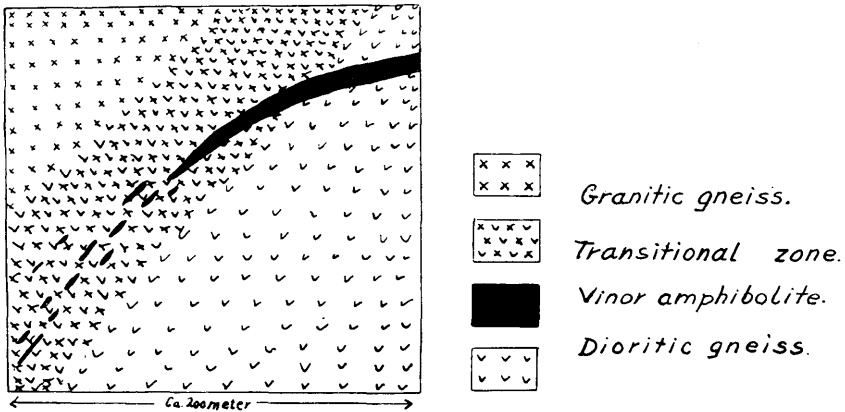

Fig. 4. Boundary between granitic gneiss and and dioritic gneiss. SE Skriverplass, Gomsrud. After C. Bugge. Author's nomenclature.

From the sketch we gather that the Vinor amphibolite has not been exposed to granitisation to the same degree as have the dioritic gneisses. The drawing also suggests a certain flow in the gneiss. The red granitic gneiss too has to some extent been erupted as a true eruptive rock. Part of the granite dykes which are found in the formation has in all probability been formed in this way. During the granitisation period the olivine hypertexte dykes have probably been transformed into amphibolites.

The Diabase Dykes of the Oslo Area.

A series of diabase dykes from the Oslo area to the east run through the formation striking more or less ENE. They are closely connected with the quartz veins. (See later.)

All these rocks with the exception of the young diabases, and to some extent the Vinor amphibolites strike almost S—N, and dip almost vertically, in the area with which we are dealing usually about 80° E. Strike as well as dip is very constant and only local and usually comparatively small variations appear. In the mine no change is found down to a depth of 1000 meters and on the surface largely the same strike and dip can be measured to an extent of about 100 km in the striking direction.

The Fahlbands.

The fahlbands are long and narrow zones where the rocks have been heavily metasomatically changed and impregnated with sulphides. They strike more or less in the direction of S—N and are almost parallel with the strike of the rocks. There are several fahlband zones the most important of which are the fahlbands of Overberget and those of Underberget. In these two zones the great majority of the mines are to be found. In Overberget the fahlband zones, which are the thickest of the district, are from 180 to 900 meters thick, and reach a length of more than 10 km (12, p. 89). Other fahlbands offer a thickness down to about two meters.

In these zones the dioritic gneiss has been metasomatically altered to biotite garnet schists, sericite schists or chlorite schists. The amphibolitic bands are altered to garnet amphibole schists,

and garnet chlorite biotite schists. These rocks are by all transitions compounded with the original rocks.

The impregnated sulphides belong to various parageneses: fahlbands derived from Vinor amphibolites by impregnation carry mostly pyrrhotite, some sphalerite and chalcopyrite and a minimum of pyrite (12) (8). Other fahlbands carry mostly pyrite with some pyrrhotite and chalcopyrite. This latter type has been thought to be genetically connected with dioritic gneiss (8).

Besides the abovementioned ordinary ore minerals, arsenopyrite, cobaltite, galena, magnetite and ilmenite have also been found in the fahlbands. Chalcocite and bornite have also been found, but they are very rare (12, p. 101).

The fahlbands are interwoven with narrow veins and lenses of quartz. This is also the case with the dioritic gneiss. The breadth of the lenses is from $\frac{1}{2}$ meter down to a microscopic size, a little less than 1 centimeter is not unusual. These lenses of quartz are cut by narrow veins of sulphides, and in several places it has been observed that the presence of a sufficient quantity of these lenses in the fahlbands will make the latter good electrical conductors. (And probably also of heat?). To these fahlbands has been attributed the faculty of precipitating silver, and they are supposed to have improved the silver content of the crossing calcite - native silver veins. (This paper p. 27.)

The rock of these metasomatically altered zones is less competent than the compact gneisses, a fact which together with their content of easily disintegrating pyrrhotite causes the surface of the fahlbands to appear as long rusty zones.

The formation of the fahlbands must have taken place before that of the Vinor amphibolites, because of the fact that the Vinor-amphibolite dykes in the fahlbands are never found to have been metasomatically altered, whereas, as we have already pointed out, the chemically and mineralogically almost identical bands in the banded gneiss have been metamorphosed to garnet-chlorite-biotite schists.

The Veins.

In the area two groups of veins are found: the older quartz veins bearing sulphides of iron, copper, zinc, and lead — and the younger calcite veins bearing arsenides of cobalt and nickel, and native silver. These groups of veins have by C. Bugge (12) been called veins of first and second generation respectively. By him the quartz veins have also been called sulphide-bearing quartz - breccia veins, a very characteristic denomination which will also be used in this paper.

The Sulphide-Bearing Quartz - Breccia Veins.

In great numbers these veins intersect the area, and they are found not only in the area where are also found the calcite - silver veins, but also to the north and to the south of it and first of all to the east where they can be traced close up to the Oslo area. They are found in the Oslo area as well, being to all probability identical with the sulphide-bearing quartz veins which have been described by V. M. Goldschmidt, and which are found at Konnerudkollen near Drammen and also in other places in the Oslo area. Part of the veins in the Kongsberg area strike more or less S—N, but the most usual strike is ENE. The dip is always very steep. It is noteworthy that the usual strike of the quartz veins (ENE) is the same as that of the younger diabas dykes, and it appears very probable that the quartz veins and the diabas dykes are genetically connected with each other. Their origin can largely be fixed to the same period. In several places in the Kongsberg area the quartz veins are found to be intersected by diabas dykes, whereas in other places we find what is to all probability fragments of diabas dykes in the quartz veins.

In several places one has found a quartz vein and a diabas dyke in the same fissure.

The thickness of the quartz veins varies from almost nothing up to more than 10 meters. A usual breadth is about 1 meter. In the striking direction they are usually quite extensive. One of the veins extends over a length of more than 6 km.

It is a characteristic feature of the veins that they usually contain fragments from the surrounding rocks; in some places to such an extent that we are justified in characterizing such veins as mineralised breccia.

Among the gangue minerals quartz is definitely the one that occurs in the largest quantities. It is usually compact and grey and often intersected by fissures. Vugs are very frequent and often contain beautiful, small transparent crystals of quartz.

The small vugs are sometimes surrounded by a zone in which the quartz has been recrystallized.

Calcite occurs in varying quantities, but the quantities cannot by far be compared to those of quartz. In the vugs and also in the veinstone we sometimes find laminiform calcite with an extraordinary well developed base as the variety *argentine*. Far W in Lassedalen I have found *argentine* replaced by quartz.

Fluorite occurs in many of the veins. It is usually green or colourless. Barite is a very rare mineral in the quartz-breccia veins. In several places zeolites occur.

The following sulphides are found; the order in which the sulphides are mentioned here is that of their relative frequency: pyrite, pyrrhotite, sphalerite, chalcopyrite and galena.

C. Bugge (12, p. 123) mentions chalcopyrite, sphalerite, and galena as silver-bearing sulphides. He gives some assays performed by himself and also assays performed by Kongsberg Silver Works and by private companies. The contents vary from 0.01 % to 0.1 % Ag. Dr. I. Oftedal (47) has made investigations with regard to the percentage of the minor components in sphalerites and galenas from these veins with an optical spectrograph. The results are given in table 2. From this we gather that the percentage of silver in galena varies from about 1 % to about 0,05 %, and in sphalerite from about 0.01 % (intermingled galena) to about 0.0005 %.

The other sulphides also contain some gold, but the investigations made have been rather sporadic. In all probability we have to deal with a percentage in the veins of from 0.00001 to 0.0003 % at most. Chalcopyrite from Liverud contains 0.0033 % Au. (Analyst R. Støren.)

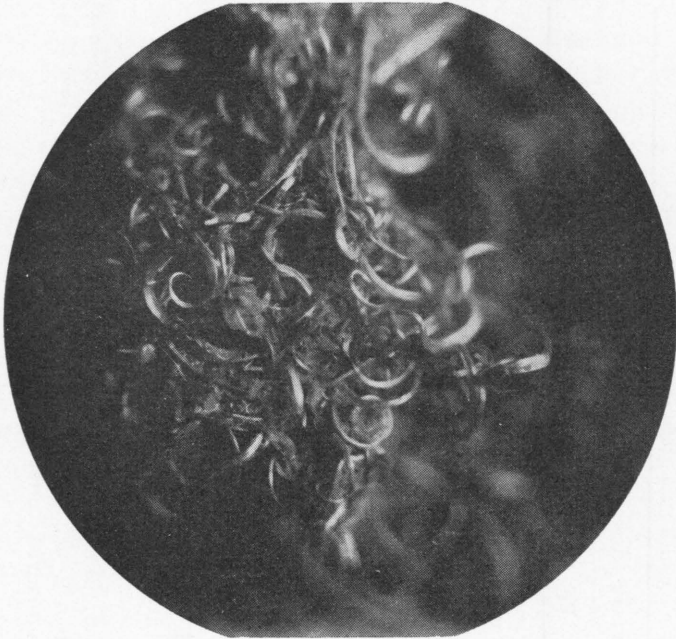

Fig. 5. Malachite in threads as pseudomorphs after native copper.
From a sulphide-bearing quartz - breccia vein in Lassedalen.

In the Lassedal vein I have found small teeth and threads of malachite. Fig. 5. They have probably originally been native copper. Native copper might have been formed secondarily from chalcopyrite in the zone of oxidation. According to Chr. A. Münster (43, p. 67) native copper with dendritic structures has been found in a quartz - breccia vein in Barlindalen.

Insufficient investigations render it impossible to state anything definite as to age sequence of the minerals. The occurrence of the minerals in the veins is rather variable. The Lassedalen mine may serve as an example. A portion of the vein is now worked for fluorite, whereas some few hundred meters from this place it was formerly worked for calcite, which was composed of coarse, snow-white and very pure crystals, a fact which made it possible to work the mine with profit.

These veins are of some practical importance because of the fact that in several places they offer the opportunity of

Sphalerite

	Cd	Ga	In	Sn	Ge	Mn	Co	Pb	Fe	Cu	Ag	Hg	As	Sb	Bi
1 . . .	1 2.1	0.03 0.015	0.01 0.010	0.01	0.001	0.005	0.01	0.03	2	0.5	0.001				
2 . . .	0.1	0.0005			0.0005						0.1	0.01		0.1	
3 . . .	0.5	0.003	0.03		0.0003	0.1	0.05	0.001	1	0.3	0.003		0.1	0.005	
4 . . .	0.5	0.005	0.0003	0.0005	0.003	0.1	0.1	0.1	10	0.1	0.005				
5 . . .	0.5	0.0003	0.005			0.5	0.03	0.3	10	0.5	0.01				0.03
6 . . .	0.3 0.20	0.0003	0.03 0.01			0.5	0.05	3	>10	1	0.005				
7 . . .	0.5	0.001	0.005			1	0.01	0.1	>10	1	0.003				
8 . . .	1	0.003	0.01	0.001		1	0.01	0.3	>10	1	0.01				
9 . . .	0.5 0.25	0.0005	0.03 0.03	0.001		0.3	0.03	0.5	>10	0.3	0.005				
10 . . .	0.5	0.001	0.01			0.3	0.05	0.03	>10	0.5	0.005				
11a . . .	0.3 0.12	0.01	0.0003	0.0005	0.0003	0.05	0.03	0.003	1	0.005	0.003	0.001?			
11b . . .	0.5 0.20	0.001	0.05 0.04	0.01 0.01		0.005	0.01	0.001	0.3	0.01	0.0005	0.003			

Table 2. Minor components in sphalerite and galena from the quartz - breccia veins. The quantities, which are given as per cents, have been estimated visually, the factor of uncertainty is 2-3. The photometrically determined amounts are added in italics, the last decimals given are comparatively correct. After I. Oftedal (47).

Table 2, cont.

Galena					
	Ag	Sn	As	Sb	Bi
1	0.05			0.01	
3	0.5		0.03	0.1	0.003
4	1			0.3	
6	0.3	0.003		0.1	0.003
7	1	0.0003		0.05	0.05
8	0.3	0.0003		0.1	0.05
10	0.3			0.1	0.05
	0.15				0.03
11	0.1			0.03	0.01

Localities: 1. Toppenhaug, Øvre Eiker. 2. Skara. 3. Skara. 4. Karlstjern. 5. Hellemyr. 6. Myrhagen. 7. Jøranrud. 8. Fiskeløysa. 9. Kjennerudvann, vein E—W. 10. Kjennerudvann, vein S—N. 11. Lassedalen, calcitic part of the vein.

mining for fluorite. In former days the mines have also been worked on silver-bearing galena and copper. The mining has sometimes been rather difficult owing partly to the uneven distribution of the ore and partly to the complex character, (Pyrrhotite, pyrite, chalcopyrite, galena, sphalerite.) Kongsberg Silver Works is at present making investigations as to the possibilities of exploiting the veins by means of modern methods of mining and dressing.

Calcite Veins.

In addition to the quartz veins we also find calcite veins of a different type from the silver-bearing ones. These veins are broader than the silver-bearing veins and they are also more extensive. Several veins of this kind are found in the southern part of the area, at Aasland, at Vierbekkvann, and at Ringtjern. In addition to calcite these veins also carry up to 30—40 % fluorite besides sphalerite and galena.

In the main driftway outside the mine Gottes Hülfe in der Noth appears a vein, portions of which has a width of several meters. This vein carries yellowish calcite and some quartz. It has been investigated over a length of several hundred meters, but it has not been found to be silver-bearing, and it is to all

probability genetically different from the native silver - nickel-cobalt-arsenide veins.

Finally we ought to mention a vein at Ljøterud. It carries calcite, hedenbergite in crystals, attaining a size of 15 cm, some pyrrhotite, and a trifle of fluorite. The vein strikes W 10° S and dips 80° N. The thickness of it is a little more than one meter. Ljøterud is situated not far from the eruptives of the Oslo area, and the vein has probably been metamorphosed by contact.

Main Veins.

Some portions of the quartz - breccia veins (these portions being those within the fahlband zones) have been permeated by the same solutions which have left the calcite - nickel-cobalt-arsenide - native silver veins. The type of vein which has been formed in this way has by C. Bugge (12) been called main veins. The main veins are often very rich in silver. They carry argentine in larger quantities than do the other veins. To some extent chalcedonian types of quartz have been formed by recrystallization. To a large extent mining has been carried out in these veins, but at present none of them are worked. The main veins often contain vugs with beautifully crystallized minerals.

The Calcite - Nickel-Cobalt-Arsenide - Native Silver Veins.

These veins have a geological appearance which is quite different from that of the sulphide-bearing quartz - breccia veins. Whereas the quartz veins occur all over a larger area, the calcite silver veins are found practically only in the fahlband zones, and from these they probably reach only seldom a few meters into the surrounding gneisses. The veins are very narrow, from a few millimeters upwards. They very seldom reach a breadth of $\frac{1}{2}$ m. The average thickness is from 5 to 10 cm. The vein proper is often surrounded by parallel and crossing fissures. The result is a mineralised zone or a mineralised breccia. These mineralised zones may in places attain the size of an ordinary sitting-room.

Sulphide-bearing quartz - breccia veins	Calcite - native silver - nickel-cobalt-arsenide veins
Found within a large area.	Found almost exclusively in the fahlband zones.
Long veins (kilometers) with a thickness of about 100 cm.	Short veins (ten-meters) with a thickness of about 5—10 cm.
Single veins.	Systems of veins.
Minerals: Quartz with sulphides of Fe, Cu, Zn, Pb. Arsenides lacking.	Minerals: Calcite with native silver and arsenides of Ni and Co. Also sulphides in small quantities.

Table 3. Showing the difference between the two types of veins
in the Kongsberg area.

The veins usually strike about E—W and dip steeply to-
wards S. However, there are also found steep dips to the north,
and dips of 45° S are common in the northern part of the fahl-
band zone of Overberget. The veins often appear in definite
systems, in trains of veins which occasionally form very beauti-
ful "Fiederspaltten". As an example of this is here given an
illustration of the system of veins of the mine Justits grube (after
A. Bugge (6)). Matters are not always as simple as in this
case. But usually the veins that are found may be brought
into systems of "Fiederspaltten". Still there exist numerous
single veins. The system of veins of the mine Justits (fig. 6)
follows a so-called striking vein; i. e. a fissure originating from
faults parallel to the strike of the fahlbands (S—N) and mine-
ralised with calcite, and sometimes also zeolites and adularia.
Slicken slides are common. The striking veins are very seldom
silver-bearing. Still they usually have been supposed to be gene-

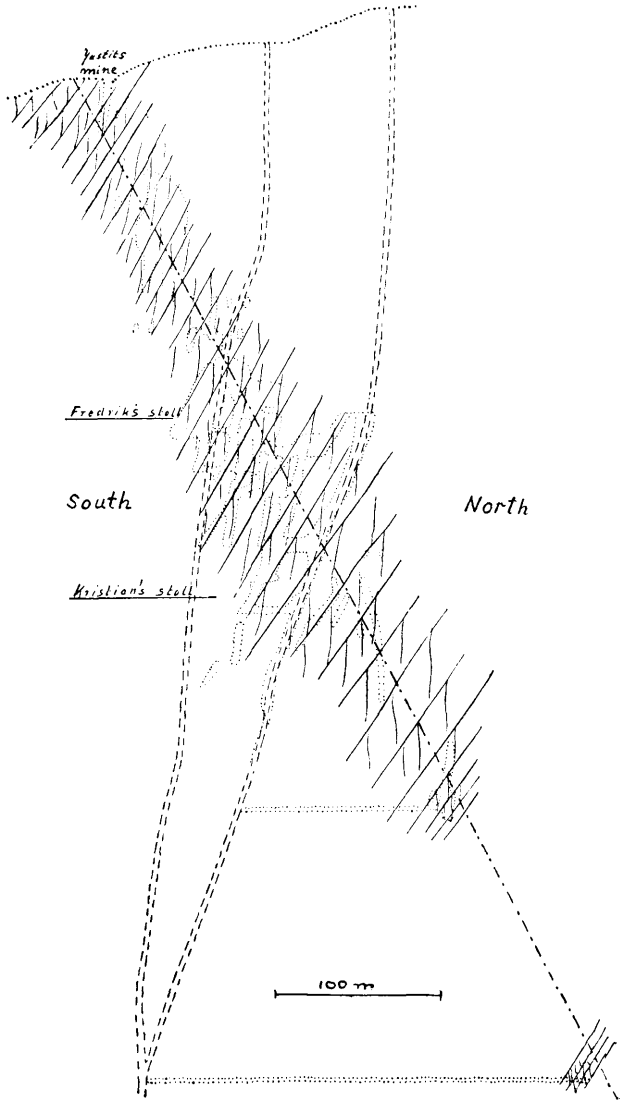

Fig. 6. The system of veins of the Justits mine.
After A. Bugge (6).

tically identical with the calcite - nickel-cobalt-arsenide - native silver veins.

The contents of silver is greatest close to a striking vein and this fact has brought C. Bugge to the conclusion that the striking veins have been channels of conveyance of the ore solutions. This does not very well accord with the fact that these veins very seldom are silver-bearing, and I am inclined to think that the causes of the regular enrichment of silver in the neighbourhood of the striking veins are purely tectonic, since the opening of the "Fiederspalten" faces the striking vein and stands vertically upon it. It is clearly seen how the veins gradually narrow and taper off with increasing distance from the striking vein. These facts have been pointed to and repeatedly mentioned by C. Bugge as well as A. Bugge.

C. Bugge has also described the "rotten veins" (råtaganger, Lattengänge) of the fahlband zones. These veins are mylonitized fissures of dislocation, striking about E—W and usually dipping 45° — 60° . C. Bugge holds that they are quartz-breccia veins that have been disintegrated and changed. They are of varying thickness, the average being about $\frac{1}{2}$ meter. The contents of the veins is a clayey mass which mostly consists of chlorite and muscovite.

Again C. Bugge has pointed out, what has also been known earlier, that in the neighbourhood of the rotten veins there will usually be found silver, and he holds that they have been of considerable importance as channels for the ore-carrying fluid. Considering the fact that the rotten veins are themselves very seldom or never silver-bearing I do not find this very likely. Nor is the compact clayey mass of which these veins consist very likely to be well suited as a means of conveyance. Personally I am inclined to look upon the "rotten veins" as maxima of tectonic influence. From these maxima the influence declines to both sides and gradually vanishes — or in other words — the number as well as the size of the veins will decrease proportionally to the distance from the "rotten veins".

As all rules of this kind this one will also doubtlessly offer numerous exceptions.

This paper is not the place for a thorough discussion of tectonics. However, I believe that a tectonic analysis of the area made by an expert in this field of science would bring important scientific and practical results. The attention of those interested in the question is drawn to the already quoted works by C. Bugge and A. Bugge where much interesting information on the subject is found.

Only an inconsiderable minority of the calcite - nickel-cobalt-arsenide - native silver veins have banded structures, which, however, occur in some veins, for example in the mine *Mildigkeit Gottes* where a large vein carries brown sphalerite to a thickness of about 1 cm close to the wall of the vein.

As has already been mentioned the veins are usually homogeneous from one wall to the other. However, we often find crystals of quartz precipitated directly on the side rock with the main axis almost vertically upon it.

Vugs are comparatively frequent. In the vugs the minerals of the veins are found as crystals of unusual beauty. Most of the ore-samples from Kongsberg, found in the museums of the world, come from the vugs. The vugs are often of considerable size; in some few cases as large as the body of a man. But the average size seems to be that of a head.

As to the amounts of the various minerals the available facts do not allow any exact statement. But from what can be gathered in the mines and from microscopic investigations it has been possible to offer for consideration the following estimates; see Fig. 7 and 8.

The distribution of the minerals in the veins is probably not in any way more variable than what is usual in hydrothermal veins; some variation is always found in veins of this kind, and of course here also. Some veins carry almost exclusively calcite and quartz. In some veins fluorite is abundant. Some carry zeolites, others do not. Only comparatively few have been found to be axinite-bearing. Some are very rich in pyrite, in others hardly a crystal is to be seen, etc. What of course has been of special interest from the beginning of the mining in the district is the variation of the silver content of the veins; a problem on which the engineers of the mining company have been working

hard for more than three centuries. Since the foundation of the Kongsberg Silver Works the so-called fahlband rule has existed. It sounds as follows: "The veins are silver-bearing only where they cross an ore band."¹ It will be noticed that the rule is a negative one. It does not say that the veins are silver-bearing where they cross an ore band, what is far from being a true statement, but it says that the veins do not carry silver except where they cross an ore band. This is in itself a disagreeable limitation for the exploitation of the mines. What makes matters worse is that it is not at all easy to decide when a fahlband is an ore band or not. It soon became clear that the richness in sulphides was not at all in itself the decisive factor. Chr. A. Münster (43) found that certain bands are good conductors of electric current and changed the fahlband rule accordingly: "The silver-bearing faculty within a particular vein must principally be ascribed to the side-rock that is the best conductor of electricity." It is mainly in this form that the fahlband rule is still adhered to, special attention having been drawn to the importance of the pyrite-impregnated quartz-lenses and quartz-veins (8, p. 107) with which the fahlbands have been more or less injected. (This paper p. 16.)

The validity of the rule has often been questioned. Th. Kjerulf (32) pointed to the lack of definition of the term ore band, and found it no wonder that the mining experts at Kongsberg maintained the general validity of the rule when by an ore band they mainly understood the side-rock of the silver-bearing portion of the vein: "The veins are silver-bearing only where they cross the side-rock at a point where the vein is silver-bearing."

C. Bugge (12) holds that in the fahlband rule the word "ore band" ought to be replaced by "fahlband". Thus the rule loses its original meaning and only states the fact that the silver-bearing veins are found within the fahlband zones.

¹ On this point the nomenclature has to some extent been rather vague. C. Bugge e. g. describes fahlbands as bands, and ore bands as fahlbands. All quotations have in this paper been transcribed to the nomenclature of this paper.

The late mr. A. Holter, M. E., formerly manager of the mines, was no adherent of the rule and has seriously warned against a strict application of the rule in the exploitation of the mines (25).

I would be very easygoing if I would rightaway deny a rule that has been applied in the mining at Kongsberg for centuries and which is still maintained by men of great knowledge in this special field. Dr. A. Bugge, for many years geological adviser of the Kongsberg Silver Works, a man who has a very thoroughgoing knowledge of this district, is one of those who are fully convinced of the validity of the rule (from mr. A. Bugge in person).

The fact remains, however, that the adherents to the rule do not at all like to be reminded of the abovementioned words of Kjerulf.

It has been tried to explain the fahlband rule chemically, and also electrochemically. J. H. L. Vogt (78) was of the opinion that the pyrite of the fahlbands has been attacked by the ore-carrying solutions and that the thus liberated hydrogen sulphide has caused precipitation of silver from the solutions as argentite. To this theory may be objected that it implies a certain proportionality between the contents of silver in the vein and the contents of pyrite in the side rocks, a proportionality that is not at all found. Also the theory implies that microscopical investigations should frequently reveal traces of this process. Such traces are not found. On the contrary, the microscopical pictures indicate that by far the greater part of the silver has been precipitated as native silver. (Undoubtedly the process mentioned by Vogt has to some extent taken place, as has also the reversing process, but neither of them may be said to have been of any great importance, judged from the quantitative results of the processes.)

Chr. A. Münster (43) has maintained that the silver of the Kongsberg area has been electrolytically precipitated by stray currents in the earth. Thus the ore bands should on account of their conductivity have operated as electrodes. To this theory must be remarked that it implies the presence of a cathode and an anode. Thus one of the walls of the vein must have operated

as a cathode and the other as an anode. This has not been found to be so. L. Tronstad (75, 76) has written papers on the problem of electrolytic precipitation of native silver and has pointed out that the silver might have been precipitated by local elements of base minerals such as pyrrhotite, pyrite, sphalerite, etc. (Cf. the wellknown experiments of Palmer & Bastin.) This theory does not imply that any of the walls must operate as cathode. But it meets with the same objection as that of J. H. L. Vogt, i. e. it implies a proportionality between the richness in ore of the fahlbands and the silver-bearing of the veins, a proportionality that is not found. Also the theory of Tronstad implies that the silver should ordinarily be found in direct contact with the above mentioned sulphides. But this is rather an exception than a rule in the veins in question.

Personally I cannot find any indication that the precipitation of the silver is conditioned by anything else than what has conditioned the precipitation of the other minerals, i. e. the decreasing temperature of the ore-forming fluid. The temperature must be expected to decrease the faster the greater the conductivity of the wall rocks. Thus Chr. A. Münster has perhaps just touched the point when he maintains that the silver must have been enriched through those fahlbands which are the best conductors of electric current, because it must be taken that these very fahlbands are the best conductors of heat also. R. Støren (69) has also suggested this explanation as the right one, as has E. Jensen (27, p. 67).

E. Jensen (27, p. 62 ff.) in this connection points to equilibria of ions of the type $n\text{Ag}^+ + \text{Me}^{m+} \rightleftharpoons n\text{Ag} + \text{Me}^{(m+n)+}$. A change of one of the factors of equilibrium e. g. the temperature will cause a precipitation of silver quite similar to a usual crystallization of a mineral from a fluid under decreasing temperature. $\text{Fe}^{3+} + \text{Ag} \rightleftharpoons \text{Fe}^{2+} + \text{Ag}^+$, e. g., will by a decreasing temperature be brought out of balance, the reaction being pushed to the left, a process which will cause a precipitation of silver. E. Jensen also mentions the possibility of similar processes taking place in the cases of manganese and cobalt. Both these elements have been present in the ore-forming solution.

Also it must be presumed that the mechanical quality of the various bands is of great importance. The bands will crack in different ways. A compact gneiss will either not crack at all, or it will develop a single open fissure. In a fahlband consisting exclusively of chlorite the laminae will slide against each other. This will make the fahlband easily give way to a tectonic influence, which will, however, not develop fissures. Between these two extremities we have the ordinary fahlbands and the ore bands. Between these two extremities we may count upon an optimal solidity, as an open fissure in a gneiss will offer an easy passage for an ore-forming fluid, which, passing rapidly without losing much of its temperature, will not allow the decomposed materials to precipitate. Where the cracks are very inconsiderable, as in the garnet-chlorite bands, they will not admit the ore-forming fluid in a quantity sufficient to produce a rich ore.

These aspects of the question have probably not earlier been sufficiently stressed.

Finally we ought to mention that in the opinion of A. Holter, (25) a great variation in the structure of the wall rocks appears to be of some importance. A structural variation in the wall rocks will imply a proportional variation of refrigeration, electrical conductivity, and perhaps also some variation of the chemical conditions (e. g. potentiality of reduction and oxydation), variations which are likely to increase the chemical activity, the precipitation, as well as the resolution of the earlier precipitated minerals.

As to the question of a systematic variation of the distribution of minerals in a vertical direction, such a variation does not appear to exist. The contents of the vein is the same whether the samples are taken from a depth of 10 meters or from 1000 meters below the surface. The only exception from this appears to be the occurrence of sulpho-salts, which are most frequent near to the surface. The only openings where they are at present found is in Mildigkeitt Gottes, about 120 meters below the surface, and in the Helgevannet Mine, about 150 m below the surface. Most of the mining is carried on at larger depths. Whereas it is nowadays a rarity to find sulpho-salts in macroscopically

visible quantities (except in Mildigkeit Gottes), they are not seldom mentioned in mining reports from former days when mining was carried on at smaller depths (from R. Støren in person). Probably we are here dealing with a very incompletely developed cementation zone.

The silver content of a vein has been said to decrease with increasing distance from the surface. (This paper p. 8.) From what has earlier been said about the veins it will be gathered that each separate vein will ordinarily dwindle against larger depths. Yet the system of veins need not necessarily dwindle, although it must be expected that a system of "Fiederspalten" will finally completely disappear, which has in several places to some extent been observed. It is, however, of great theoretical interest that no observations have been made which might suggest a systematic change of the mineral content of the vein itself because of increasing depth.

If it is possible to prove the theory of a dwindling of the silver towards larger depths, a theory which must be said to be at the present state of research rather hypothetical, such a dwindling must be altogether ascribed to tectonic causes.

The Origin of the Veins and the Physical Conditions Attending their Formation.

It has been commonly supposed that the sulphide quartz-breccia veins as well as the calcite - native silver veins have been formed by hydrothermal activity subsequent to the eruptive activity in the Oslo area, by which activity were formed the alkaline rocks of the latter area, and I cannot find a single factor to oppose that theory. As far as the quartz veins are concerned the matter seems quite obvious. These veins are geologically connected with the diabase dykes of the Oslo area and they seem to be formed together with or slightly earlier than these dykes. But also with regard to the calcite - native silver veins there seems to be every reason to believe in the parentage of the youngest granite in the Oslo area, the Drammen granite, named after the town Drammen. This is the youngest eruptive rock found in this country. If we are to throw doubt on the connection

between these veins and the Drammen granite, we shall have to operate with hypothetical eruptives in the depth, eruptives, the presence of which have not in any way been ascertained.

It has been suggested (46) that veins of the type in question must be genetically connected with basic eruptives. With regard to that suggestion I should like to point to the fact that within the geological unit to which the area belongs there are found no rocks younger than the granite, except the diabase veins mentioned. The theory of the origin of the calcite - cobalt-nickel-arsenide - native silver veins from a basic rock implies that this rock must have been older than the sulfide-bearing quartz - breccia veins. On the contrary they are younger.

There is no convincing proof of the parentage of the Drammen granite, but all indications point in that direction and to doubt it is to introduce unnecessary complications.

If the above mentioned origin be accepted, it is possible with some accuracy to make an estimation of the pressure under which the veins have been formed. At Kongsberg the present surface is close below the sub-Cambrian peneplane. At the end of the period of eruption in the Oslo area this peneplane was under the pressure of:

- 1) Cambro-Silurian sediments.
- 2) basic lavas and rhomb porphyries.
- 3) acid lavas(?). Remnants of these are nowhere to be found.

The total thickness of these strata in this area is not known with certainty. They have been removed by erosion. The thickness has by J. H. L. Vogt been estimated to 3 km, an estimation which is probably not very far from the truth. This corresponds to a pressure at the present surface of 800 atm., and to a pressure at a level which is at present to be found at a depth of 1000 m (the bottom of the mine Kongen grube) of somewhat less than 1100 atm. Thus roughly estimated the veins have been formed under a pressure of 1000 atm.

As regards the temperature under which the formation has taken place it is obvious that in the case of the veins at Kongsberg the temperature cannot be fixed with certainty. We must try to arrive at a starting temperature and a closing temperature of the complete genesis of the minerals. It is characteristic of

this paragenesis that it includes high temperature minerals such as axinite, and medium temperature minerals such as barite and albite, as well as low temperature minerals such as zeolites. It is quite probable that the formation of minerals has continued until the cooling down of the solutions to the temperature of the surrounding rocks. Counting in what was at that time the recent volcanic area an increase of temperature of 6° C per 100 m depth and a total depth of 3500 m we arrive at a temperature of about 200° C. At this temperature the younger primary minerals probably were precipitated. For the oldest minerals belonging to the same part of the paragenesis as the axinite a temperature of 400° — 500° C does not seem improbable (this paper p. 95). At what temperature the silver has been precipitated is hard to say. It can only be conjectured.

These estimates of the interval of temperature for the formation of the minerals of the veins are to some extent supported by the results of experimental investigations. I have tried to arrive at the temperature of formation of certain minerals by means of the method based upon the existence of inclusions in crystals.

The principle of this method will here be briefly sketched. If we imagine a crystal during the process of crystallization as it grows including a drop of the solution from which it has been precipitated, further cooling will create in the cavity a portion of gas besides the liquid, the volume of the latter diminishing because of the cooling. The result of this process is a two-phased inclusion such as is often seen in minerals. At Kongsberg they are found in quartz, fluorite, and axinite. If a mineral containing such a blister is heated, we will find that the gas inclusion will dwindle and finally completely disappear. The temperature of the mineral at the moment of the disappearance of the gas inclusion will then be the temperature under which the mineral has been formed. If the temperature under which the mineral has been formed is considerably more than 150° C the temperature found by this method will be apt to be somewhat too low because of the greater compressibility of water under higher temperatures.

I made several experiments, but none of them led to the complete disappearance of the gas inclusion.

A crystal of quartz was heated to 230°. At this temperature the immersion liquid (soya oil) turned opaque. The gas inclusion was then very small.

A crystal of fluorite with a number of two-phased blisters was heated to 270°. At this temperature the gas inclusions were still rather considerable, but their further development could not be observed as the crystal cracked. The inclusions, however, all reacted in the same way, which suggests that they are primary.

As this method should not be applied at temperatures higher than 150° C further experiments were not made. The results, however, to some extent confirm the calculations above.

The minerals.

In the course of time the minerals from Kongsberg have been the objects of numerous investigations. This has particularly been the case during the latter half of the last century, when many research workers have been occupied with them. The two most informatory works have been written by Ths. Münster (44) and L. Sundt (74). R. Støren (69, 70, 71, 72, 73) and E. Jensen (27) have in recent years been particularly interested in native silver and the conditions of its formation.

Below are given the minerals which are known from Kongsberg. The minerals have been arranged according to a system worked out by H. Strunz (68) on crystallochemical principles. This arrangement has also been maintained during the following discussions of the several minerals.

Native silver	Tetrahedrite-tennantite
Native arsenic	Niccolite
Dyscrasite	Pyrrhotite
Argentite and acanthite	Minerals of the sternbergite
Jalpaite	group
Sphalerite	Galena
Chalcopyrite	Stephanite

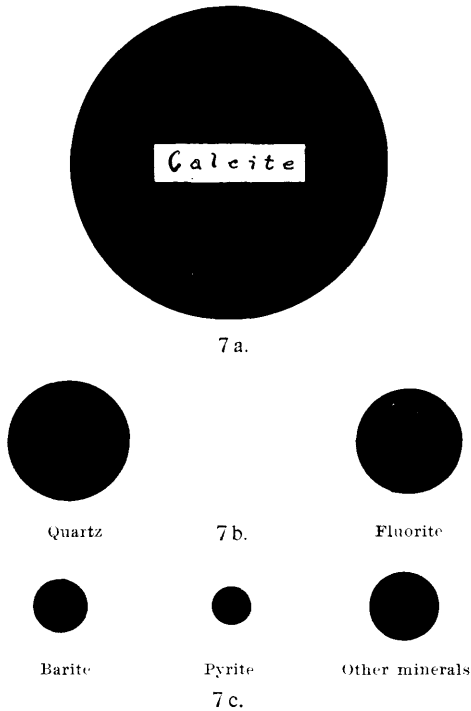

Fig. 7. Illustration of the approximate relative quantities of the more commonly occurring minerals of the veins. The quantities are proportional to the areas of the circles.

- | | |
|--------------------------|-----------------------|
| Polybasite | Prehnite |
| Ruby silver ore | Asbestos (Chrysotile) |
| Pyrite | Apophyllite |
| Marcasite | Chlorite |
| Diarsenides of Ni and Co | Armenite |
| Chlorargyrite | Hyalophane |
| Fluorite | Albite |
| Quartz | Datolite |
| Anatase | Natrolite |
| Calcite | Laumontite |
| Barite | Stellerite |
| Erythrite | Harmotome |
| Epidote | Coal blend |
| Axinite | |

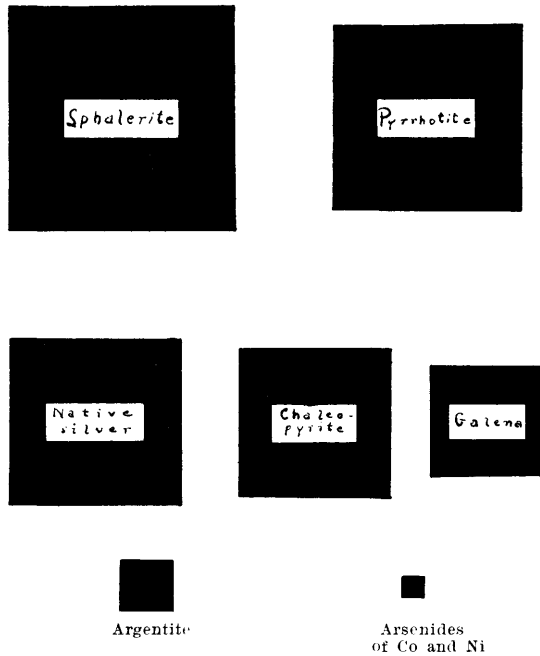

Fig. 8. Illustration of the approximate relation between those minerals which do not occur in large quantities in the veins. The quantities are proportional to the areas of the squares.

In addition, older works mention arsenopyrite (p. 73), and J. Lietz (35) maintains to have found a new mineral, for the time being called mineral b (p. 64).

These minerals occur with an extremely varying frequency and distribution, from calcite, which fills most of the vein fissures, to anatase and armenite, each of which is known from one single specimen only. Now it must be borne in mind that it is practically impossible to get exact information about the percental share of the various minerals in the veins. But, walking about in the mines and making microscopical examinations of the ores, one will eventually arrive at a conception of the relative quantities of the minerals. In spite of the fact that such a conception will be a very subjective one and not easily approved of by the scientist who will demand exact proofs and facts, I will in this case not abstain from expressing my personal conceptions, hoping that they will not prove too far removed from truth.

In fig. 7 I have represented the average, relative quantities of the predominating minerals, whereas in fig. 8 I have pictured those minerals which are not dominating in the veins. The areas of circles and squares respectively are proportional with the average percentages of the minerals.

The figures need no particular comments. It will be noticed that calcite is completely dominating, and that the sulphides occur in relatively small quantities. The relative percentages of native silver and argentite should also be noticed.

Native Silver.

For more than three hundred years the mines at Kongsberg have been worked for native silver. It is therefore quite natural that just this mineral has been the chief object of discussion and that a considerable series of printed and unprinted theses and descriptions on this mineral, its occurrence, its forms of development, and its composition, are available.

Native silver occurs mostly in three different ways:

1) As enclosed silver (“fyllingssølv”), where the outer form is not dependent on crystallographic factors, but decided by the form of the surroundings.

2) In filiform forms, as what is at Kongsberg called “trådsølv”, thready silver, i. e. curved fagots of threads or hair which have often grown together.

3) As crystals limited by well defined crystal faces.

In addition silver occurs as coatings round argentite and produced from the latter.

“Enclosed silver” is probably the most common occurrence. Often it shows a lot of mouldings of other minerals such as e. g. quartz. Often silver is found precipitated in small fissures in the surrounding rocks. A small fissure may be found filled with silver and nothing but silver. Thus are produced thin laminae limited by parallel walls. These laminae should not, however, be confused with laminiform crystals of silver, which will be described below. In some places such silver-filled fissures occur in large quantities in the surrounding rocks close to the vein, thus forming an excellent ore.

Thready silver, too, is rather common. Descriptions of thready silver from Kongsberg are numerous in the literature of mineralogy. An excellent description has been given by E. Jensen (27, p. 69), who I am here quoting (in translation): "Thready silver are long, curled and twisted formations with a characteristic streaking parallel with the length direction. The diameter of the threads may be from fractions of a millimeter to several centimeters, and the length may be several centimeters. Because of this variability the various threads are very often of a different appearance. There appear long, thin threads or curled rods, and also short, thick horns or veritable balls of fine fibre. — Usually the lower, broader end of the thread is found to be fastened to one mineral or another, making it look like growing up from this mineral. — All the threads which I have examined show some common features. First of all there is the characteristic way in which they "grow" up from the substratum. They are easily broken at the base, and the surface of fracture shows no zone of reaction nor any continuation down into the sulphide. (Rather: down into the substratum. Remark by the author.) A microscopical examination of the streaking shows that all of them have crystal faces. All those specimens, the surfaces of which are unmolested, show in these planes a steppe construction of small, sometimes very small crystal faces. In some few larger threads this may be seen with the naked eyes. Already J. H. L. Vogt (78) points to the fact that ordinary thready silver occasionally shows indications of a crystalline surface. This all seems to indicate an upbuilding of the threads from long, small crystals arranged parallel with the length of the threads. The various threads very often look like bundles of crystals, and often less complicated threads appear to have joined, thus making thicker, more complicated forms. Even when macroscopically a thread looks comparatively even and smooth, in the microscope it will **because of this construction of crystal faces show an uneven surface, offering sharp edges and reentrant angles between the latter.**"

Thready silver has been given various forms, e. g. hair silver (hårsølv), and tooth silver (tann sølv); aggregates of smaller threads orientated in all directions will look like moss,

and has been called moss silver. This latter type is rather common. Very curious forms are found, reminding us of wonderfully twisted roots or old deformed trees. I have seen examples of one single thin small thread of silver having been spooled round itself in such a way as to make a ball.

This curious mineral has of course for a long time interested the mineralogists. The mineral was first produced artificially by R. J. Haiiy in 1801 simply by heating argentite, on the surface of which then appeared threads of silver. Later thready silver has been produced many times, and in many ways. All these methods show the common feature that the mineral is produced from argentite, or by the influence of a sulphide on a solution of a silver salt. It might thus be suggested that primarily argentite has been produced, and then in turn from argentite has been produced thready silver.

The first one to produce thready silver from a hydrous solution under conditons similar to those which must have been present in nature, was E. Jensen (27) in 1939. He found a development of threads of silver on argentite when this mineral was at a temperature of 130° C exposed to hydrous solution of copper sulphate and ferrous sulphate or to a solution of potassium antimonyl tartrate and silver sulphate. Further he exposed stibnite to a hydrous solution of silver sulphate. By this process threads of silver were produced. In the same way cobaltite will also give thready silver. By exposing solutions of silver sulphate containing antimony to the minerals sphalerite, galena, pyrrhotite, argentite, and chalcopyrite under a temperature of 130° C there will be formed thready silver, whereas the same minerals do not precipitate thread-shaped silver from silver solutions which do not contain antimony. Evidently antimony plays an important part in the formation of threads, and E. Jensen (27, p. 99) has formed the following rule: “— — — whenever metallic silver is formed from a solution containing antimony in the presence of any sulphide (not necessarily silver sulphide) it is filiform”.

Further he has (27, p. 79) by the following fine experiment been able to show, what has also been suggested by the study of the structure of the threads, that the growth of the threads

of silver takes place at the root of the threads and not at the top: A cylinder of silver sulphide was heated in hydrogen. As soon as macroscopic threads had appeared a trifle sulphur was introduced into the cylinder in order to give the threads produced a coating of silver sulphide. When the threads had been allowed to grow for some time the experiment was interrupted, and as a result he obtained a series of silver threads which were blackened at the top but clean and white at the root of the thread. Taking for granted, what is very likely, that the threads of silver will grow in the same way in a liquid as here in a gas, it may be concluded that the growth takes place from the root of the thread.

E. Jensen's view of the formation of threads is this: Thready silver is formed from argentite (or acanthite) by the removal of sulphur or by the binding of sulphur to some other component, whereas the released silver traverses the sulphide until in one place or another on the surface it encounters a crystal embryo of native silver on which it is precipitated and where eventually a thread is formed. Finally then the formation of thready silver should be dependent on the free mobility of silver ions in silver sulphide.

It is evident that a small silver crystal on the surface of argentite in this way will have new substance precipitated on the plane along which it has been affixed to argentite, and only on that plane, and that the result of this growth will be a long thin crystal, i. e. a thread. I find it quite natural that during its growth this thread will easily be flexed. If now originally a lot of small (parallel) crystals are found arranged side by side the result may be a long tooth of native silver consisting of a series of quite thin threads which have more or less grown together. Besides, there must evidently during the growth of the bundle of threads be formed new threads besides the older ones, because the teeth of silver are usually thicker at the root than farther up. As to the bended and partially twisted forms, they ought not to surprise us when we bear in mind that a tooth of silver or a thread of silver will consist of a series of threads which are more or less grown together; if now the various threads composing such a bundle or tooth do not grow exactly at the same

rate, there will immediately be created tensions in the bundle of threads, and these tensions will cause the bundle to bend or twist.

Now, as regards Jensen's view in the formation of thready silver, that this formation should actually depend on a specific particularity of silver sulphide, several things have brought me to doubt that this constitutes the whole story. First of all we should then always expect to find argentite as the substratum of filiform silver. This is, however, not the case. At all events it must be right to suppose that argentite has just acted as a medium; that is to say, during the growth of the silver threads from argentite, this again has drawn corresponding quantities of silver from the solution. Thus a rather small quantity of argentite is able to bring about the crystallisation from a solution of relatively larger quantities of silver in the form of thready silver. E. Jensen, too, seems to have just touched this idea.

However, I do not think that this explains everything. It is of some interest to examine more closely the host minerals on which thready silver has been deposited, i. e. argentite, pyrrhrite-proustite, pyrite, and galena. In the case of these minerals sulphides are always present, and where the sulphides is not silver sulphide, we might imagine that this sulphide has first been produced in some quantity, and then thready silver. However, thready silver is also deposited on a substratum of native silver, and even calcite is found as a host mineral, that is to say we find host minerals which show a complete lack of any sulphur. In the mines I have found large quantities of beautifully developed thready silver without noticing even a trifle of argentite, and neither I, nor as far as I know, any one else, have been able to ascertain that argentite is in any way more common where thready silver occurs than where other forms of silver are found.

Neither does the above mentioned view of the deposition of thready silver offer any explanation of the important part which, as already mentioned, seems to be played by antimony in the deposition of thready silver. Here various explanations might be suggested. Thus intermediately produced dyscrasite might have played the part which has, according to above men-

tioned view of the matter, been played by argentite. Also Sb^{3-} in dyscrasite might by a temporary change to Sb^{3+} act as a redoxy-catalyst in the reduction of Ag^+ to Ag . But theories like these must needs be hypothetical as long as they are not proved by reliable and exact experiments. A continuation of the experiments made by E. Jensen is very much to be wished and welcomed and might throw further light on this interesting phenomenon of nature, the deposition of thready silver.

A form of silver which when cursorily examined looks very much like thready silver, but which will appear somewhat more solid, has by R. Støren been called baroque silver or baroque crystals of silver. It appears in tooth-like and very twisted shapes which have been so called because of their baroque appearance, and which are, as is also hinted in the name given to this form of silver, to a large extent limited by crystal faces. The streaking parallel to the length of the forms which is so characteristic to thready silver, is here either completely lacking or only traces are left. This form of silver can scarcely be regarded as anything else than more or less recrystallized thready silver.

Native silver in crystal forms limited by well defined crystal faces and comparatively "normal" development is by Chr. A. Münster (43, p. 49) said to be very rare. "The all important part of the silver is found in lumps, plates, teeth, threads, and shells; months and years may pass between every time crystals are found." This is correct in so far as beautifully developed crystals are very rare, but silver showing crystal faces is far more common than appears from the description just quoted. (Actually thready silver has also crystal faces, but because of its peculiar development and formation it is not included among what has been called "crystallized silver"). Of course there is in the first instance no genetical difference between "enclosed silver" ("fyllingssølv") and "crystallized silver", and in a direction along which it can grow freely, enclosed silver may very well show independent crystal faces, in which case it must be looked upon as something in between. I have, however, included this way of classification, because these names are much used and are practical denominations very descriptive of the

appearance of the silver. A closer examination of the silver which is not thread-shaped will show that most of it shows larger or smaller crystal faces.

We often find dendritic forms produced by the joining together in one crystallographic direction of smaller crystals exhibiting parallel orientation. The common crystallographic direction has then been dominating during the growth of the forms. These dendritic crystals may remind very much of large crystal skeletons. Often they assume the shape of a tree with branches or the like. The dendritic forms have been examined by A. Sadebeck (60). A considerable part of the so-called moss silver consists of aggregates of small dendritically developed crystals which are orientated in various directions.

Crystals of silver from Kongsberg have been examined by several research workers, first by G. Rose (57) who in 1831 described crystals with dominating (311) and subordinate (111) and in addition twins after (111) with large (111) faces and smaller (100) faces. K. Zittel (82, p. 793) mentions (111), or (111) and (100) sometimes combined with (110), and finally rather thoroughgoing examinations have been made by A. Sadebeck (60). Some of his drawings of crystals are here reprinted as Fig. 9, Fig. 10, and Fig. 11. In all he has diagnosed the following faces: (111), (100), (110), (311), (210), (410), (520), and (751). As a middle habitus he gives octahedron in equanimity with cube or tetrahedron.

Twins, tw. pl. (111), are very common. They may be penetration twins, the corners of one individual protruding from the cube faces of the other like noses, a configuration which is well known from fluorite. The twins may also be contact-twins. In the collections of the Kongsberg Silver Works is found a crystal, a picture of which is printed as Fig. 12. The two individuals are limited by the cube-faces and are with reentrant angles joined along an octahedron face. The greatest length measured in the twinning-plane is 4 cm, and the greatest breadth vertically on this plane is 3 cm. This is probably the most beautiful silver crystal ever found.

In addition to these twins others are also found according to A. Sadebeck (60): “. . . . ferner sind aneinander-wachsungs-

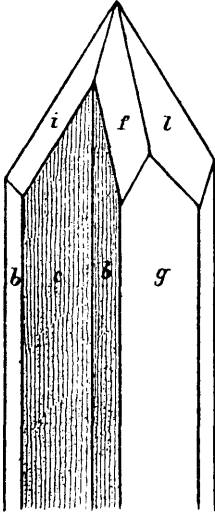

Fig. 9.

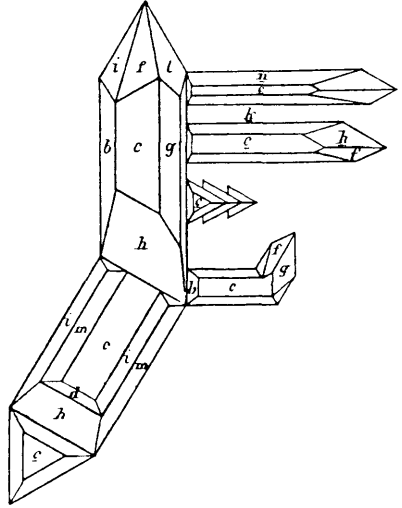

Fig. 10.

Fig. 9. Twin crystals of silver. b, c octahedron faces. f, g, i, l trapezohedron faces. After A. Sadebeck (60).

Fig. 10. Twin crystals of silver. b, c, d octahedron faces. f, g, h, i, k, l, m, n trapezohedron faces. After A. Sadebeck (60).

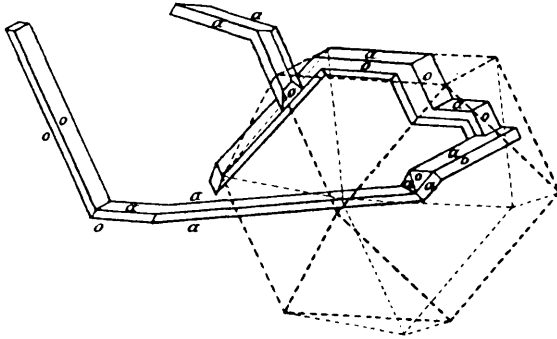

Fig. 11. Twin crystals of silver. a = cube. o = octahedron. After A. Sadebeck (60).



Fig. 12. Twin crystals of native silver. Natural size.

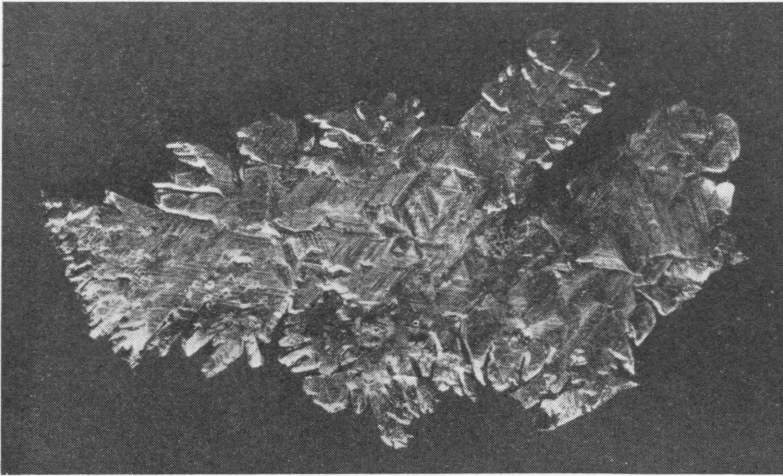

Fig. 13. Lamini-formed crystal of native silver.

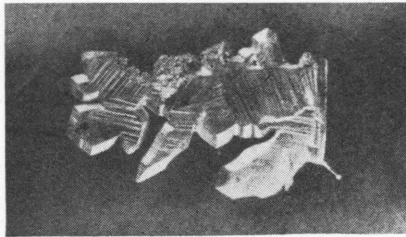

Fig. 14. Small lamini-formed crystal of native silver.

zwillinge verbreitet bei den Ikositetraedern m (311), wie schon G. Rose (loc. cit.) hervorhob. Diese Zwillinge haben oft ein trigonales oder hexagonales Aussehen."

In the year 1934 very beautiful lamini-formed crystals of silver were found in a vug in the mine Gottes Hülfe in der Noth, 230 m level. As early as 1935 R. Støren (73) published a description of these crystals. In the crystal found in Fig. 13 the large faces are about 20 cm², whereas the thickness of the plate crystal is only 1 mm, the dimensions being thus approximately 30 mm . 70 mm . 1 mm.

A closer examination shows that the large faces are octahedron-faces and that the plate crystals are twins with (111) as twinning-plane. In accordance with this we sometimes find angles on the small edge. On the large shining planes of the octahedrons we find a triangular streaking after (100) due to oscillatory combination of the forms (111) and (100). Under the binocular-lens we may easily see a weak development of the (100)-faces.

The flaps in the edge of the crystals are limited by a tetrahedron. The faces did not allow any quite exact measuring, but it must be quite certain that we have to deal with (520). A crystal on which such a flap has been very well developed is found in Fig. 14.

It is a well known thing that twins are often extremely developed along the elements of twinning. Thus twins which have a twinning-plane are flattened along this plane, whereas twins which have a twinning-axis are lengthened in the direction of the axis. The described plate crystals are examples illustrating this rule.

The plate crystals were found together with uncommonly much argentite, and there also occurred ruby silver ore (73). These facts indicate the possibility that we are here dealing with a younger product belonging to the cementation zone.

The chemical composition of native silver has for long periods been the object of investigations. We may mention names as Langberg (33), Samuelsen, and Stalsberg and also Chr. A. Münster (42), and recently investigations have first of

all been made by E. Jensen (27), J. Lietz (35), and R. Støren (69, 70).

Mercury is the element which in the largest quantities is present in native silver. From numerous analyses which have been made it is possible to give an average percentage of 1—2 %. It varies very much from specimen to specimen, from very small percentages to amalgames which are very rich in Hg. In all the following percentages have been determined larger than 5 %: 5.06 % (Pisani), 5.50 % (Samuelsen), 7.20 % (Flight), 7.28 % (Støren), 13.7 % (Pisani), and 23.07 % (Flight). Two crystallized amalgames with percentages 4.74 % and 5.06 % have caused Pisani to isolate a mineral species for which he proposes the denomination Kongsbergite. Now Ag and Hg form mixed crystals of the α -phase under all conditions up to 50 % Hg. Thus the proposed denomination ought to be excluded from the mineralogical nomenclature. Pisani himself was also very reserved and suggested the possibility of this connection not being a stoichiometric one.

Samuelsen wanted to prove that the amalgames in question were not stoichiometric, and to that effect he selected a piece of silver containing mercury, which by hammering and by steadily moving the specimen in one direction under the hammer was given a longish and thin form. In that end of the piece where he had started the hammering he could finally only find traces of mercury, whereas the other end of the piece contained no less than 4 % Hg. In the opinion of Støren a consequence of this experiment is that mercury should mainly occur near to the surface of the silver crystals. I have found it possible to explain this by suggesting that silver has derived its mercury in the following way: Silver being the more electropositive element has precipitated mercury from the solution, immediately binding it by amalgamation. Mercury stands below silver in the electro-motive series of elements, according to Handbook of Chemistry and Physics, 21st ed.: $\text{Ag} = \text{Ag}^{2+} + e$, potential -0.7978 ; $2 \text{Hg} = \text{Hg}_2^{2+} + 2 e$, potential -0.7986 . It is, however, astonishing that mercury has not been equally distributed in the silver crystal in question by diffusion during the long period which has elapsed since the formation, and in harmony with this J. Lietz found

(35, p. 105) two crystals which he examined layer after layer from the surface to the core, to contain largely a constant percentage of mercury. The small variation observed was a slight increase in the percentage of mercury from the surface towards the middle and then again a decrease towards the center of the crystal.

We ought to bear in mind that from the moment of the beginning of the deposition of native silver, this mineral must have precipitated mercury from the solutions. This fact offers the possibility of native silver being alloyed to mercury during its own precipitation if the solutions in question have contained mercury.

Much interest is attached to the fact that thready silver shows a far smaller percentage of mercury than other forms of native silver. It has even been maintained that thready silver should contain no mercury at all. This supposition has been confuted by the spectrographical examinations made by J. Lietz (35, p. 106). However, it has been definitely stated that the percentage in thready silver is on the whole considerably smaller than in other forms of silver. This must probably be explained by taking thready silver to have been deposited slightly later than common native silver, at a point when the main portion of the available mercury had already been deposited. — According to J. Lietz the younger plate crystals which have been described above contain only 0.001 % Hg. The difference as to percentage of mercury has probably no connection with the difference which is in principle found between native silver which has crystallized from the ore-forming solution like most minerals, and on the other hand thread-shaped native silver which has grown from a substratum.

The percentage of antimony present in the silver has to no such extent been made the object of investigations. Chr. A. Münster (42, p. 278) has made two determinations and found 0.58 % Sb and 0.01 % Sb and J. Lietz (35) gives approximately > 0.1 % for 12 tests, 0.1 % for 4 tests, 0.01 % for 2 tests, 0.001 % for 1 test, and < 0.001 % for 3 tests. These investigations indicate an average percentage of Sb of 0.1 %. We must not, however, disregard the possibility of a small percentage of

dyscrasite which might exclude the presence of antimony in native silver. Yet, bearing in mind that dyscrasite is rarely found in polished specimens, whereas Sb is very common, it is a more likely supposition that this comparatively inconsiderable percentage of Sb has been taken in solid solution by native silver.

Gold is strikingly rare. Systematic investigations made at the smelting-works of the Kongsberg Silver Works in the years 1852—1882 and after 1915 show an average percentage of Au of between 0.001 % and 0.005 %. Silver from some small mines which have not been of any great practical importance show larger percentages, up to 0.35 % (22).

As a mineralogical rarity silver containing much more gold has been found. This silver has been called golden silver (*gyldisk sølv*). The following percentages have been determined: 29.9 %, 27.4 %, 28 %, 31.8 %, 32.5 %, 34.2 %, 43.9 %, 45 %, 50 %, and 53.1 %. The figures are interesting in so far as usually auriferous silver has proved to contain less gold than indicated by these figures, *electrum* more.

Golden silver has been found in the following mines: Louise Augusta, Charlotte Amalie, Juel, Braunschweig, Hannibal, Blygangen, Fräulein Christiane, Beständige Liebe, Vater Adam, Mutter Eva, Vinoren Nr. 9, Nye Segen Gottes, Blårud, and Ravnås. Th. Hiortdahl (22) has pointed to the fact that on the rock dumpings from many of these mines are found quite strikingly many pieces of gangue which must have originated from quartz veins, and he thinks that this must indicate a connection. We must bear in mind that the sulphide-bearing quartz-breccia veins will carry a trifle gold, 2—3 g per ton at the most. Probably the ore-forming solution of the native silver-nickel-cobalt-arsenide veins when forcing its way along the older quartz vein, has not been in equilibrium with gold, which element has then been selectively extracted from the quartz vein, and later redeposited as golden silver together with the other minerals of the younger native silver-nickel-cobalt-arsenide paragenesis.

As a consequence of this interpretation we may state that gold (in larger quantities than 0.005 % of the silver) is an element which has not originally been present in the veins under discussion.

Samuelsen maintains to have found 5.5 % Pt in gold gained from native silver. This corresponds to a percentage of about 0.0001 % Pt in the silver. He also maintains to have proved the presence of Pd.

The possibility of the presence of some copper in the silver cannot be disregarded. Most of the copper which has been observed to all probability originates from chalcopyrite; during his spectrographical investigations J. Lietz has found 3 specimens showing Cu and not Fe, or too little Fe in relation to the percentage of copper. If the presence of copper in the silver can be proved it must be a very small percentage, on an average 0.001 % at the most; personally I am inclined to believe that no copper is present in native silver, the only indications of the presence of copper being the above mentioned statements by J. Lietz, and a calculation like his of the percentages of copper and iron by means of a spectrogram may very well bring in an error of a factor of ten or more.

Other elements found together with silver without doubt originate from other minerals occurring together with the silver, Ni from the Ni-Co-arsenides, Pb from galena, and Fe from pyrrhotite etc. Bi offers a more difficult problem. Either Bi must have followed the arsenides, or the small percentage of Bi, 0.001 % at most, must have been included in the silver as a solid solution. The first explanation is the most probable one, the spectrographical results arrived at by J. Lietz showing some proportionality between the percentages of Ni, Co, and As on one side, and the percentage of Bi on the other. However, J. Lietz gives 0.001 % Bi for a specimen which does not contain any Ni or Co. Now we must bear in mind that J. Lietz has availed himself of a visual comparison of the spectrographical lines of native silver and those of metallic silver to which have been alloyed certain known quantities of those metals which are of interest in this connection. This must be regarded as an inaccurate method which demands a very cautious use of the data found.

The paragenetical position of the silver (see the map showing the paragenesis, p. 126) seems to be quite clear, the minerals of the quartz - coal blend - fluorite - axinite - pyrite

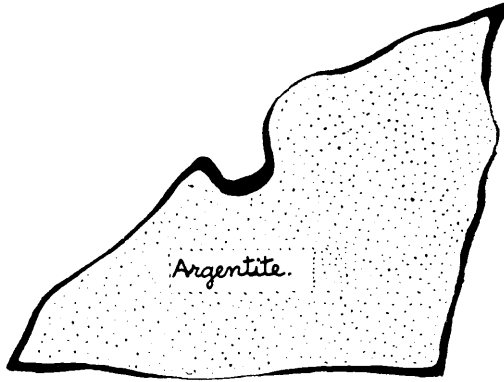

Fig. 15. Surface of argentite changed into native silver.
After J. H. L. Vogt (78).

paragenesis, and in addition the older sulphides and most of the precipitated fluorite and calcite, being older, whereas the Ni-Co-arsenides, pyrrhotite, and the second generation of the other sulphides are younger.

Quartz, pyrite, and axinite show crystals bordering against silver. Besides silver has been precipitated in fissures in these minerals. In addition quartz has sometimes been replaced by native silver. This is also, but not so often, the case with pyrite (Pl. I, Phot. 1). The older sulphides are also replaced by silver (Pl. I, Phot. 2).

The silver is cut through by thin veins of the younger sulphides and the Ni-Co-arsenides together with calcite (Pl. II, Phot. 3, Phot. 4), and the Ni-Co-arsenides, pyrrhotite, and sometimes chalcopyrite are found as coatings on crystals or smaller portions of silver. As to the arsenides a more thoroughgoing discussion of this structure is found on p. 74 ff.

Between native silver and argentite the relations are very intimate. Sometimes one of these minerals is found together with the other. Argentite is found changed into silver from the surface onwards (Fig. 15), the metamorphosis may be found so advanced that only a small nucleus of argentite is left in the middle of the silver. On the other hand we also find examples of a thin coating of silver on argentite, this coating sometimes being so thin that it is observed as a light grey hue on the surface. The metamorphosis of argentite to silver during the

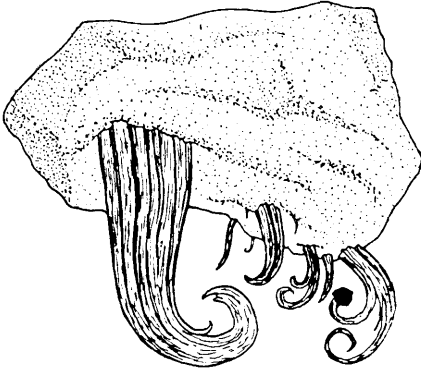

Fig. 16. Silver threads on argentite.
After J. H. L. Vogt (78).

formation of thready silver has been described above (Fig. 16). On the other hand we also find a conversion of silver into argentite, the process starting from the surface. This process is sometimes found so far advanced as to leave but a small nucleus of silver. As a result of this process we may as a rarity find "thready argentite", which is, however, usually connected with remnants of silver indicating its origin.

Any considerable difference as to age between thready silver and common native silver has not been indicated by the investigations. On the contrary, the two forms seem to have been formed on the whole contemporaneously. However, as mentioned above, the low percentage of mercury might suggest that thready silver is slightly younger, a supposition which is supported by the fact that as a rarity, thread-shaped forms are found on the surface of common native silver.

The paragenetical position which has here been described must be applied to almost all native silver. However, in those portions of the occurrence which are close to the surface, has been found silver which has been decomposed and redeposited or crystallized. This silver is found together with more argentite than usual and also together with ruby silver ore, and it must be supposed to have been deposited from descending waters.

In addition very small quantities of younger silver of hypogene origin have been observed. This silver has probably been formed through a temporary faculty of the solutions, though to a very small extent, of decomposing silver that has been precipitated

earlier. This decomposed silver has then later been deposited from the solutions. Thus I have come across an isolated example of a small native silver vein in pyrrhotite. This silver must without doubt be younger. Some few times I have observed features which might indicate a later recrystallization of older silver. This, however, seems to be a process which must have played a very inconsiderable part.

Arsenic.

Native arsenic is a very rare mineral in the veins. I have myself never found this mineral, and the collections of the University, Oslo, include only 5 specimens of it. Arsenic has in former days been mentioned from Vinoren and from the mines at Helgevann.

Three specimens which were put at my disposal by the Geological Museum of the University of Oslo, were closely examined. One of them came from Christianus VI at Vinoren, the other two are labelled Kongsberg only. In the microscope it appeared that the three specimens are all tolerably similar, consisting primarily of arsenic in which have been separated quite small portions of antimony, the latter partly appearing as drops. (Pl. III, Phot. 5.) Besides, similar portions of native silver or dyscrasite and of ruby silver may be seen. What distinguishes native antimony from native arsenic is a more yellow colour. Native antimony is also brighter and softer.

An optical spectrogram which Dr. I. Oftedal had the kindness of making for me shows the following minor components:

Sb	1	%	Pb	0.00x	%
Ag	1	-	Hg	0.00x	- in two specimens only.
Cu	0.0x	-	Ni	0.00x	- in one specimen only.
Te	0.0x?	-	Bi	0.001	-
Co	0.0x	-			- in two specimens only.

In addition Ca, Fe, and Si from the gangue.

It must be regretted that because of the war it has not been possible to make a chemical analysis of these three specimens as was originally intended.

The specimens consist of an aggregate of crystals of arsenic, the size of the grains being similar to that of rather finely crystallized lump sugar. In my opinion the mineral has under a higher temperature been an alloy of As, Sb, and Ag. The atomic radii of these elements are 1.40 Å, 1.61 Å, and 1.44 Å respectively. The present structure is secondary and is produced by unmixing caused by sinking temperature.

Native arsenic occurs together with calcite, which it probably replaces. As we do not know any more of its mode of appearance than what is mentioned here it is impossible to know whether it has been precipitated by ascendent or descendent waters. The fact that nowadays we never find native arsenic may indicate that it does not occur at the larger depths where mining is now carried on, but only at higher levels where the mining was carried on earlier. This might indicate that it has been precipitated from descendent water. The structure described above, which is probably due to unmixing, on the contrary seems to indicate that it has been produced under such a high temperature that it must imply ascendent waters as depositing fluid.

Since the mineral in places exhibits a botryoidal surface a gel has probably first been precipitated. By crystallization this gel has become an aggregate of small crystals of an alloy of As, Sb, and some Ag. Under decreasing temperature there have been produced by unmixing portions of antimony and silver (or dyscrasite) in native arsenic.

Dyscrasite.

Dyscrasite appears to be rather rare. Besides, when this mineral does not occur in direct connection with silver, it is easily interchanged with the latter mineral. In addition it also appears in quite the same way as silver, and when these two minerals are found in direct contact with each other, both of them occur in irregularly limited portions, and their borderings on each other do not give materials for conclusions as to their relative ages, or for conclusions as to whether one mineral has been formed from the other by replacement, or as to whether

they have been produced contemporaneously. Often dyscrasite is found to have an edge of native silver, whereas I have also on the contrary found silver which has had its edges changed into dyscrasite.

Argentite and Acanthite.

These minerals are rather common in the veins, but they nevertheless do not constitute more than 10 % of the silver at the most (see fig. 8, p. 36). Usually they appear as irregularly limited masses or as laminae between other minerals. By far more seldom are found crystals, and these have then nearly always been corroded. Ths. Münster (44) strikingly remarks that argentite looks as if it had been exposed to heat and to some extent started melting.

G. vom Rath (56, p. 385) describes crystals with predominantly cube and dodecahedron, and also trapezohedron (211), and Schrauf (1871, p. 165) describes (111), (110), (211), and under some doubt (221). In the collections of the Kongsberg Silver Works is found a beautiful crystal with dominating (100) which is barely cut by (111). There is also found a penetration twin consisting of two individuals limited by cube grown together in such a way as to make the corners of one individual pierce through the planes of the other individual like small noses. However, it is probably most likely that this latter example is a pseudomorph of argentite after native silver. In the same collections are also found several crystals with rhombic habit and to some extent developed into spear-like shapes. It must be regretted that the faces are too poor to allow measurements by means of the goniometer, but they are probably crystals of acanthite.

When one succeeds in getting a good polish on specimens of argentite, it may clearly be noticed that the mineral is anisotropic. By means of colour filters and inexactly crossed niccals we will then usually find differently orientated lamellae and stripings. Yet the lamel-formed structure cannot be said to be very striking. However, taking into consideration how easily such a structure may be overlooked, because of the fact that argentite will usually not polish very well, and also because

of the weak anisotropy, I think it quite consistent to conclude that the occurring argentite will commonly be lamel-structured and thus formed under a temperature higher than 179° C. I will not omit pointing to the fact that the observations of J. Lietz (35, p. 95) has lead him to the opposite conclusion, i. e. that silver sulphide although sometimes perhaps formed at temperatures higher than 179° C as argentite, has usually been formed at temperatures lower than 179° C, as rhombic acanthite. Here theory stands against theory, and it must be regretted that we have no means of decidedly and irrevocably settling this question, which is of such a great importance to the right understanding of the paragenesis of the occurrence.

Besides having been formed in the zone of cementation, argentite has obviously been formed in two generations. The oldest argentite has been formed contemporaneously with the older generation of sulphides, and has often been replaced by native silver. Some portions of silver have only small remnants of argentite left. Around the silver has later been precipitated Ni-Co-arsenides. The younger argentite is younger than native silver, which it replaces. In polished specimens may be seen how in this way coatings have been formed round silver, quite similar to those which are formed by Ni-Co-arsenides. The younger generation of argentite is probably of the same age as the younger generation of the other sulphides.

Now as to the hypothesis put forth by J. H. L. Vogt (78) that the greater part of the native silver at Kongsberg should have been formed secondarily from argentite, it appears from the microscopical examinations as well as from what may be observed in the mines, that he has to the highest degree exaggerated the importance of this process. The justification of his supposition demands a frequency of the occurrence of argentite as residual portions in silver by far much greater than what is observed. Also the process must be expected to have left traces directly in the veins.

The mutual replacement of argentite and silver, which is also well known from other occurrences, where it is often difficult to follow in details, seems to be easily conceived in the case of the Kongsberg occurrence. Argentite of first generation (see

the table of paragenesis, p. 117) has during the deposition of silver not been in equilibrium with the solutions and has been replaced by native silver. By this process often only a thin protective coating has been formed. On the other hand native silver has during the deposition of the younger generation of argentite been replaced by the latter mineral. However, it is probably most likely that the younger generation of argentite consists in native silver which has been changed into argentite by the sulphide-depositing solutions. Thus the younger generation should not imply any fresh introduction of silver into the veins. I have not found any indications of the conditions of the mutual replacement of argentite and native silver being more complicated than here sketched, the only exception being the redeposition which has taken place in the upper regions of the occurrence under the influence of descending water. Native silver as well as silver sulphide, probably in the form of acanthite, is found in the incompletely developed zone of cementation. They have probably been formed during new mutual replacement phenomena.

Jalpaite.

Personally I have never found jalpaite, but J. Lietz describes it from the mine Kongens grube as well as from Gottes Hülfe in der Noth. In a specimen from the latter mine, 636 m level, jalpaite occurs together with argentite and chalcopyrite and replaces the latter mineral.

Jalpaite must be exceptionally rare.

Sphalerite.

Next to pyrite, sphalerite is probably the most frequently occurring sulphide of the Kongsberg veins. Yet it occurs only in comparatively small quantities (Fig. 7 and 8). The colour varies from light yellow to dark brown and black, corresponding to a greatly varying percentage of iron. Crystals of sphalerite are very scarce. Specimens from Christians stoll (driftway of King Christian) have been examined by A. Sadebeck (59, p. 620, 61, p. 595). According to this author the positive tetrahedron dominates. The negative tetrahedron is less developed. Be-

sides, the crystals are limited by the cube. The positive tetrahedron has lines pointing to a dodecahedron, and the negative tetrahedron has lines suggesting a very flat triacistetrahedron. He has also found the usual twins after (111).

I. Oftedal (47) has examined sphalerite from these deposits spectrographically. The results of the analyses are given in table 4. He has especially pointed to the fact that the Kongsberg sphalerite is exceptionally rich in silver, and is of the opinion that this is due to interpositions of silver-bearing minerals. However, neither Oftedal nor I have ever been able to observe such interpositions by microscopic examinations. A few observations made by Oftedal himself might indicate the correctness of his proposition. The spectrographed sphalerite from the mine Gottes Hülfe in der Noth (Table 4, 1) often has a peculiar metallic lustre on the surface of fracture. A collection of specimens taken from such surfaces of fracture proved to contain 10 times as much silver as the rest of the crystal. Another crystal of sphalerite from Kongsberg was light green within and dull and green on the surface. The dull portions were richer in silver than the glossy ones, and this may probably indicate that the lack of lustre is due to a pigmentation with some silver-bearing mineral. It is, however, rather curious that even under very high magnifying powers (1000—1500 times natural size) it has not been possible to discover any such interpositions. We therefore probably have to take into account the possibility that the comparatively large quantity of silver may be due to solid solution.

An x-ray spectrogram of sphalerite from Mildigkeit Gottes, 124 meter level, shows, in addition to Zn and Fe, also Cu and Mn, in perfect harmony with the results arrived at by I. Oftedal.

Sphalerite occurs in two generations in the veins, one older than native silver and the other younger than native silver, the nickel-cobalt-arsenides and pyrrhotite. (Fig. 39.) (Pl. III, Phot. 6). The older sphalerites are characterized by interpositions of chalcopryrite, which are lacking in the case of the younger. This is in excellent harmony with the common supposition that these interpositions have been produced by unmixing due to the lower solubility of CuFeS_2 in ZnS by lower temperatures than

Sphalerite															
	Cd	Ga	In	Sn	Ge	Mn	Co	Pb	Fe	Cu	Ag	Hg	As	Sb	Bi
1	0.3	0.001	0.003			0.3	0.01	0.001	>10	0.1	0.01	0.003			
2	1	0.01	0.0001		0.0001	0.1	0.005	0.03	1	0.01	0.01	0.003		0.03	
3	3	0.05		0.001	0.001			0.1			0.1	0.003		0.01	
4	0.3	0.001	0.0005	0.005		0.005	0.05	0.03	0.5	0.005	0.001	0.003			
5	0.05	0.001	0.0003	0.001	0.0003	0.005	0.03	0.001	0.5	0.005	0.001	0.003			

Galena					
	Ag	Sn	As	Sb	Bi
1	1	0.001		0.1	0.005
2	0.1			0.1	
4	0.01			0.03	0.001

Localities: 1. Gottes Hülfe in der Noth. 560 m level. 2. Mildigkeit Gottes. 3. Mildigkeit Gottes.
4. Old Anna Sophie mine. 5. Kongsberg.

Table 4. Minor components in sphalerite and galena from the calcite - nickel-cobalt-arsenide - native silver veins. The quantities, which are given as per cents, have been estimated visually; the factor of uncertainty is 2—3. After I. Oftedal (47).

by higher. The older sphalerite has been produced under higher temperature and has absorbed some CuFeS_2 in solid solution, whereas the younger sphalerite has been produced at lower temperature and has only been able to absorb inconsiderable quantities of CuFeS_2 , and thus no unmixing processes take place under decreasing temperature.

Whether the percentage of iron is dependent on the temperature of formation (and consequently of the age) or not cannot be definitely stated, but various observations have already caused me to believe that the dark sphalerite must be the older one, a supposition which is very well supported by the spectrographical examinations made by I. Oftedal, which shows that the percentage of iron and that of copper vary proportionally. (Tab. 4.) Accordingly the percentage of iron must be highest in the older sphalerite.

Chalcopyrite.

Chalcopyrite occur in two generations, one older which is paragenetically connected with the older sphalerite, and one younger which is paragenetically connected with pyrrhotite and the arsenides of Ni and Co.

Part of the available copper (and iron) was when sphalerite was formed absorbed by this latter mineral in solid solution, and later under decreasing temperature separated by unmixing as the well-known interpositions of chalcopyrite in sphalerite. But part of it at the same time crystallized as pure chalcopyrite. It cannot be microscopically distinguished from the younger chalcopyrite except on the background of its relations to other minerals.

That we are here dealing with a younger generation is distinctly conceived, however, from the fact that chalcopyrite will over and again appear together with calcite, pyrrhotite, Ni-Co-arsenides and to some extent also with pyrite as younger veins in silver. (Pl. II, Phot. 3.) Besides, we often find the mineral as thin crusts around native silver in the way which is characteristic to rammelsbergite and chloantite.

Most of the chalcopyrite which is found probably belong to the younger generation, but it goes without saying that usually

it is not possible to state whether a grain of chalcopyrite found in a polished specimen belongs to the older or the younger generation.

As a rarity crystals of chalcopyrite are found in vugs. These crystals are not suited for closer examination by means of the goniometer, but as far as may be gathered there appear in addition to common twins, also five-fold twins after (111) and repeated twins after (101).

As is the case with sulphides in general, chalcopyrite occurs very rarely. (Fig. 8.)

Tetrahedrite - Tennantite.

This mineral must be said to be very rare. In the polished specimens which I have examined I have found it only once, and then in a specimen from the mine Kongens grube, 520 m level, where it was found together with chalcopyrite as a rest after replacement in silver. In some of the ores examined by J. Lietz (35) it appears that tetrahedrite - tennantite has occurred somewhat more frequently. One of the statements of the above mentioned author runs as follows: "Meistens tritt es (tetrahedrite - tennantite) in kleinen Körnern oder Verdrängungsformen auf, die fast immer in Beziehung zum Kupferkies stehen", thus evidently in the same way as in the specimen examined by me. This indicates that tetrahedrite - tennantite must be supposed to have been formed contemporaneously with the older chalcopyrite, and it must thus be conceived as a not frequently appearing member of the calcite - barite - sphalerite - chalcopyrite - galena - marcasite - (pyrite) paragenesis. (This paper, p. 118.)

We know some very few crystals of tetrahedrite - tennantite. An x-ray spectrogram of one of these shows Cu as a main component, and in addition strong lines of Zn and Fe, the α -lines of these elements being almost equal. Ag-lines did not occur, having, as will be remembered, a very unfavourable place in the spectrum. The lines of As and Sb are about equally strong (vacuum spectrograph). The spectrogram does not allow of any conclusions as to the respective proportional quantities of As and Sb, but it does indicate that both elements are present.

In the collections of the University of Oslo there is a crystal of chalcopyrite covered by a coating of tetrahedrite - tennantite. Such relations between these two minerals are well-known from other occurrences, and is due to the near relationship between the atomic structure of the minerals.

Niccolite.

Niccolite is comparatively common in the veins. As an illustration it might be stated that niccolite is found in approximately every 7th polished specimen. But it is always found in very small quantities.

The diagnosis does not cause any difficulties; a red colour of the mineral and its distinct pleochroism and anisotropism announce its presence.

The most usual mode of appearance of niccolite is in small lumps in the Ni-Co-diarsenide-crusts round native silver (p. 74). These small lumps are probably replacement remnants. But it is also possible that niccolite has been formed contemporaneously with the other arsenides and in smaller quantities than these. I have never found structural features from which might be drawn consistent conclusions on this point.

That niccolite is younger than native silver is gathered from the fact that it is found in veins, and also in quite small veins which shoot into or run through native silver. These veins contain the following minerals: calcite, chalcopyrite, pyrrhotite, Ni-Co-diarsenides, and niccolite (Pl. II, Phot. 3, Phot. 4).

In one single polished specimen only I have found niccolite as an independently occurring crystal, about 0.5 mm across. This crystal was surrounded by a coating of chloantite, the thickness of which was about 0.005 mm. This coating must without doubt have been made by replacement of niccolite by chloantite.

In another specimen niccolite, rammelsbergite and chloantite occur together. Here niccolite is found as small portions within the aggregate of arsenides, and it seems to be beyond doubt that this mineral is the oldest one, the two others having been formed by replacement of niccolite.

Thus while a series of indications are found to the effect of niccolite being the oldest one of the arsenides, I have never found any indications of its not being so.

Pyrrhotite.

Microscopical examinations have shown that pyrrhotite is a more frequently occurring mineral than has been earlier believed. (Fig. 8.) Among the sulphides, pyrite and probably also sphalerite are more common, whereas chalcopyrite and galena present themselves in smaller quantities.

Often pyrrhotite appears as a coating around native silver in the same way as do the arsenides of Ni and Co. Pyrrhotite shows replacement structures in connection with native silver, and is without doubt younger. (Pl. IV, Phot. 7.)

Pyrrhotite is also found together with the oldest minerals e. g. axinite. Thus it is found in the specimen containing armenite from the mine Armen. Therefore we have to reckon with an older generation which, however, occurs comparatively seldom.

Pl. I, Phot. 2 shows how pyrrhotite and native silver cutting through older sphalerite with interpositions of chalcopyrite. Pyrrhotite is thus paragenetical with silver and slightly younger.

Polished specimens often show that pyrrhotite along its border to the surrounding minerals has a seam of a distinct shade of colour which is somewhat browner than the colour of the contiguous portions.

In vugs it is not uncommon to find beautiful and well developed crystals. G. v. Rath in 1869 (56, p. 441) writes enthusiastically of a magnificent gangue specimen containing crystals of an outstandingly beautiful appearance — “Aufgewachsene Krystalle, dicke Tafeln begrenzt von der Basis und einem neuen, unbestimmten, sehr spitzen Dihexaeder, dessen Seitenkanten etwa 160° messen”. Kenngott (30) describes crystals limited by (0001), $(10\bar{1}0)$, and $(10\bar{1}1)$, and with Sp. G. = 4.584. The crystals occur together with native silver, fluorite, and calcite. A. Streng (67) describes a crystal occurring together with native silver and calcite and limited by $(10\bar{1}0)$, (0001), and (2243). Streng uses Seligmann's axial ratio of 1:1.6502.

X-ray spectrograms of pyrrhotite from the mine Kongens grube show no other elements than iron.

Minerals of the Sternbergite Group.

These minerals must be very rare at Kongsberg. In one single mineral only I have found a mineral which as to colour, pleochroism, and anisotropism was similar to pyrrhotite, but which was less hard than native silver and chalcopyrite. The colour was perhaps a little darker than that of pyrrhotite. This cannot be but a mineral of the sternbergite group. No conclusions can be made as to the paragenetic relation of the mineral.

Mineral b.

From the mine Kongens grube and the mine Gottes Hülfe in der Noth, 650—700 meter level, J. Lietz (35, p. 74) describes a mineral with the following qualities:

It polishes approximately as well as does chalcopyrite.

It is just a little harder than chalcopyrite.

As to colour and refraction, it is almost similar to pyrrhotite. The colour of this mineral though, is a little more brownish than the more reddish one of pyrrhotite.

Pleochroism and anisotropism could not be found. The mineral is not corroded by nitric acid in the course of 5 seconds.

The mineral appears as very small grains, usually together with chalcopyrite. A spectrogram of a substance which could not be made quite free of chalcopyrite, native silver and Ni-Co-arsenides, showed:

Fe very distinct lines.

Ag distinct lines.

Ni weak lines.

Cu weak lines.

The necessary quantity of substance for a chemical analysis was not available to J. Lietz, who for the present applied to this mineral the denomination: Mineral b.

During my work I have not found this mineral at all.

Galena.

Galena is rather rare, and I have not often found it in the polished specimens.

The age of the mineral I have not been able to determine with any degree of reliability, but it occurs in the same way as

the older chalcopyrite, and is probably produced contemporaneously with this latter mineral. Younger galena of the same age as younger sphalerite is to all probability also found.

Galena is usually not very well crystallized. From the collections of Kongsberg Silver Works is known a specimen the crystals of which have a size of one centimeter and are intergrown with native silver. The crystals are heavily corroded and their form is almost globular.

I. Oftedal has examined galena from Kongsberg spectrographically. The results of his examinations are given in Table 4, p. 59. Personally I have taken two x-ray spectrograms of galena. In one of them I found only the lines of lead, in the other also weak lines of zink and copper, these elements probably originating from interpositions of sphalerite and chalcopyrite.

Stephanite.

Stephanite must be counted a rarity, and it appears in still much smaller quantities than pyrargyrite — proustite.

In a polished specimen from Gottes Hülfe in der Noth, 624 m level, stephanite may be seen together with ruby silver in native silver. Stephanite surrounds pyrargyrite (Pl. IV, Phot. 8) and evidently must be looked upon as a reaction rim by replacement of silver by pyrargyrite. This process must have taken place according to these formulae:

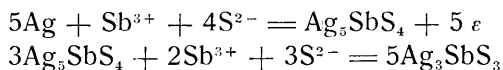

Besides being an oxydation the process also represents a deposition of antimony and sulphur.

The material of observation is, however, so limited that we cannot disregard the possibility of the process having taken place in a way directly opposite to this, native silver having then replaced pyrargyrite during the formation of a reaction rim of stephanite.

In the mine Haus Sachsen, stephanite is known from about a 450 m level.

In Christian VII, one of the mines near Helgevann, I have found stephanite in a polished specimen from the 150 m level,

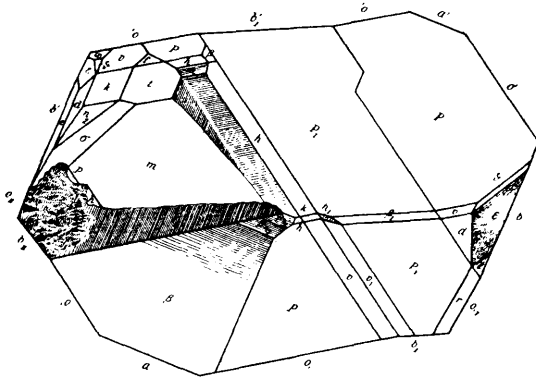

Fig. 17. Stephanite from the mine Gottes Hülfe in der Noth, ca. 400 m level
After Carl Morton (40).

stephanite having replaced native silver in a coating of chloantite. A nucleus of silver is still left (Pl. V, Phot. 9). Here we have, however, to reckon with the possibility of stephanite being a supergene product. In the ores from this locality pyrrargyrite - proustite is known as secondary minerals. In addition to these localities, stephanite also occurs in small quantities in the ores from Mildigkeit Gottes, 124 m level.

In the microscope stephanite is grey with a touch of roseate. The hardness is much less than that of silver, but greater than that of argentite. The mineral polishes well and is markedly anisotropic, brownish and bluish-green shades of colour in the diagonal positions. The mineral differs from the rest of the sulphosalts of silver in so far as it does not exhibit internal reflection.

Ths. Münster (44) has found small crystals of stephanite in a vug in the so-called "north vein" (nordgangen) in Gottes Hülfe in der Noth, about 400 m level. He holds that stephanite is one of the youngest minerals, formed at the same period as laumontite (?). One of these crystals has been examined by C. Morton (40) who identifies the faces c (001), o (110), a (100), b (010), P (111), r (221), h (112), w (131), v (132), f (133), ϑ (152), ε (2.22.7), β (101), e (041), d (021), k (011), t (023), $\underline{\beta \frac{2}{3}}$ (203), $\underline{\beta \frac{1}{2}}$ (102), $\underline{n_2}$ (156), $\underline{\sigma}$ (258). The faces which are underlined were for the first time observed on this crystal. Morton's illustrations are here given as Fig. 17 and Fig. 18.

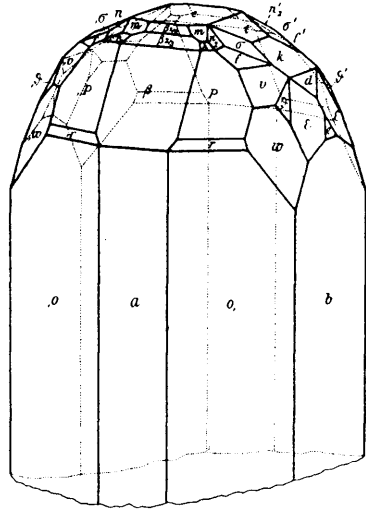

Fig. 18. Idealized drawing of stephanite, the same crystal as fig. 17. After Carl Morton (40).

Polybasite (-Pearceite).

This mineral is as far as can be gathered exceptionally rare. However, it is possible that it may in reality be somewhat more common than what is my conception of the matter, considering the fact that we cannot disregard the possibility of mistaking this mineral for argentite as well as pyrargyrite - proustite, which latter minerals, however, usually differ much from polybasite by exhibiting far more distinct internal reflections.

In the few cases where I have regarded the diagnosis to be quite unmistakable, polybasite has occurred in columnar forms together with a sulphide which in turn must have been a remnant of replacement in native silver. This mode of appearance has earlier been described by J. Lietz (35) and I reprint here two of his illustrations as Fig. 19 and Fig. 20. Evidently these structures cannot be interpreted in any other way than by supposing that polybasite is older than native silver and paragenetic with the older sulphides.

It should be very natural to suppose that all the occurring sulphosalts, when primarily produced, should belong to the same part of the mineral deposition, and this taken for granted, the mode of appearance of the polybasite indicates that pyrargyrite,

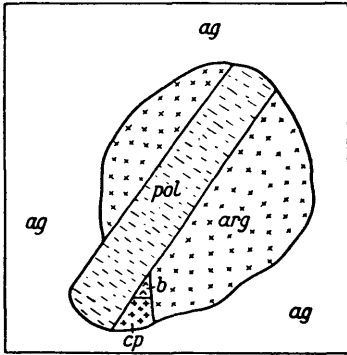

Fig. 19.

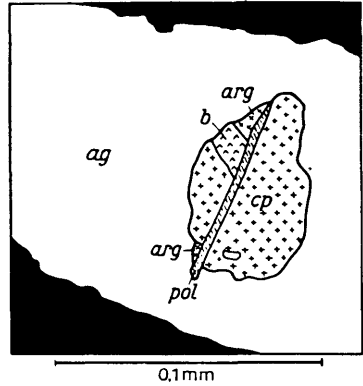

Fig. 20.

Fig. 19 and 20. pol. = polybasite. b = mineral b. cp = chalcopyrite. arg = argentite. ag = silver. Gottes Hülfe in der Noth, 690 m level.

After J. Lietz (35).

stephanite, and polybasite belong to the same paragenesis as the older sulphides, sphalerite, chalcopyrite, galena, and argentite. However, the special way in which polybasite occurs makes this conclusion somewhat doubtful, and I am more inclined to believe that polybasite and the two other sulphosalts must have been produced in quite different ways and to different periods, polybasite having been crystallized from the ore-forming fluid with a crystal form of its own, contemporaneously with or slightly earlier than the older sulphides, whereas pyrargyrite and stephanite have been produced by replacement of native silver in the way described when dealing with these latter minerals.

Pyrargyrite - Proustite.

These minerals occur in comparatively moderate quantities and are to all probability rarer than e. g. arsenides of Ni and Co (Fig. 8). With the exception of some few localities at small depth, pyrargite - proustite may almost be said to be a rarity. It is, however, certain that it occurs as a primary mineral. We find occurrences of it e. g. in the mine Gottes Hülfe in der Noth at such a large depth as 608 m level. Here the mineral is found in silver close to the rim of the silver grains. The genetical

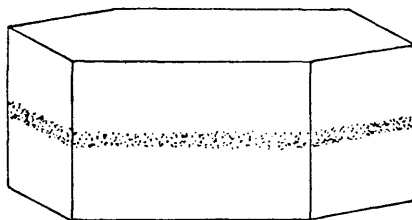

Fig. 21. A crystal of calcite pigmented with pyrrargyrite in a zone parallel to the base.

conditions cannot be stated with certainty, but probably it has replaced native silver. The contrary process is, however, also possible. If so, the ruby silver must be conceived as representing replacement remnants in native silver. There seems to be certain relations between pyrrargyrite - proustite and the arsenides of Ni and Co.

The predominant portion of ruby silver ore which is found has been precipitated at smaller depths. Thus e. g. the ore of the mine Mildigkeitt Gottes, 124 m level, is unusually rich in these sulphosalts. They are also found in the mine Bratteskjerpet, at about a 100 m level. These ores probably represent an incompletely developed zone of cementation. (For a closer discussion see this paper p. 30—31.) In Pl. V, Phot. 10 it is seen how the younger pyrrargyrite - proustite has replaced calcite and native silver, but not chloantite. Sometimes pyrrargyrite - proustite is seen to have replaced native silver along the borders of the grains making a coating around this mineral, this coating being from the point of view of structure completely identical with the usual coatings of Ni-Co-arsenides.

It is well known that it is very difficult to tell pyrrargyrite and proustite from each other in the microscope. In order to decide which of these minerals is the most commonly occurring, I have taken some random samples and made microchemical tests after M. N. Short (66). The ruby silvers which I tested, turned out to be pyrrargyrite.

In the collections of the Institute of Technology in Trondheim is a crystal of calcite limited by hexagonal prisma and base. It is pigmented with pyrrargyrite in a small portion parallel to the base. (Fig. 21.) Pyrrargyrite has evidently been precipitated from the solution contemporary with the host mineral and has

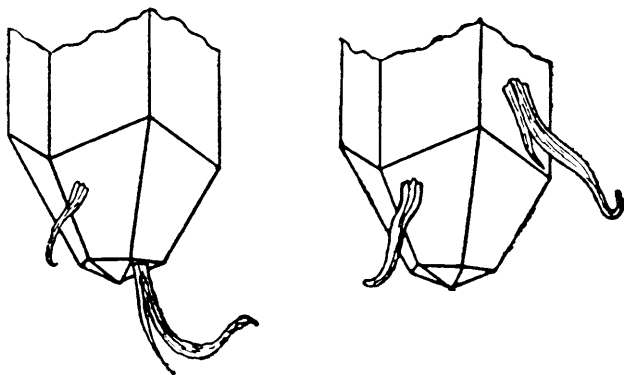

Fig. 22. Proustite with hairs and thin threads of native silver.
After J. H. L. Vogt (78).

then pigmented the faces of the calcite during the growth of the latter. Also many harmotomes from Kongsberg have been coloured red by a pigment, which probably, as in the above mentioned example, is ruby silver. The pigmented minerals here mentioned are perhaps supergene products.

J. H. L. Vogt (78) gives a picture of crystals of proustite (Fig. 22) on which have grown threads of native silver. The crystals of proustite are limited by "ein spitzen und ein stumpfes Skalenoeder nebst Säule".

Pyrite.

Pyrite is the most frequently occurring sulphide of the veins. It is usually developed in crystals with pyritohedron or cube as surrounding faces. According to Durocher (16) pyrite has also been found surrounded by icosahedron.

Pyrite has to all probability been precipitated during the whole process of formation of the veins. It is known as one of the oldest minerals precipitated directly on the wall of the vein, and also in some places the rock close to the vein is impregnated with pyrite, a mode of appearance which may be seen in some places in the mines Bratteskjærpet and Mildigkeit Gottes. On the other hand pyrite is known as a very young mineral, found e. g. together with argentite and portions of the youngest quartz in the cavities between laths of argentite.

On page 94 has been described a paragenesis: axinite, epidote, pyrite. I have made an x-ray spectrogram of a pyrite from this paragenesis without finding any other element than iron.

Pyrite that probably has been derived from marcasite is described on page 72.

Pyrite is sometimes found replaced by calcite, native silver, and argentite. As a rule, however, pyrite is very little corroded, and this agrees very well with the theory that the mineral, as has been mentioned, has probably been precipitated during the whole mineralizing period.

Marcasite.

Marcasite is a rather rare mineral in these veins. In the collections of the University of Oslo, at Blindern, is found a specimen in which marcasite occurs together with pyrite in twins after (110). Fig. 23.

In the reflection microscope this marcasite shows a high anisotropism and no indication of metamorphosis. It is not stated exactly where this specimen has been found. We cannot disregard the possibility of its being a supergene formation.

In the mine Haus Sachsen, 480 m level, and in the mine Kongens grube, 520 m level, has been found marcasite which has been replaced by native silver, thus producing a characteristic graphic structure. (Pl. VI, Phot. 11, Phot. 12.) This marcasite shows anisotropism in one of the examined grains only. In this grain a twin bordering occurs, bringing the anisotropism into relief. The fact that anisotropism is seldom found thus might indicate that marcasite has to a great extent been changed into pyrite. Where metamorphosed marcasite and primary pyrite occur together in the perspective, pyrite is distinguished by a distinct green colour (side by side with native silver), whereas marcasite is grey with a touch of bluish-green.

Its hardness is greater than that of pyrrhotite.

In order to arrive at the greatest possible reliability it was desirable to have an optical spectrogram as well as a Debye-Scherrer-diagram.

Dr. I. Oftedal had the kindness of examining the marcasite - native silver - symplectite spectrographically, and found that it

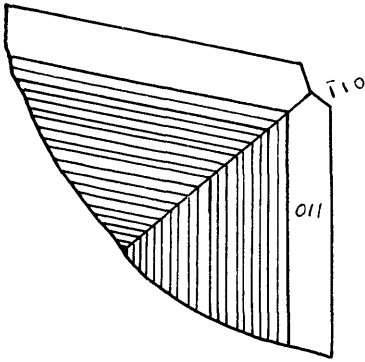

Fig. 23. Part of a twin of marcasite. Tw. pl. (110) Striation edge (001)—(011) due to oscillatory combination of the two forms.

contained large percentages of Ag and Fe, rather little Cu, Ca, Pb, and Cr(?), and no As or Sb at all.

Mr. H. Major showed me the kindness of taking two Debye-Scherrer-diagrams, the one of symplectite in which marcasite showed anisotropism, and another in which it did not.

It is not possible by means of the diagrams to identify even the slightest indications of marcasite in any of the specimens, whereas the lines of pyrite are quite distinct. The change into pyrite must thus be rather far advanced, however, not so far as to make the anisotropism indistinct. Bearing in mind that in a Debye-Scherrer-diagram the lines of orthorhombic minerals will be by far much weaker than those of isometric ones, I do not find it improbable that a mixture of e. g. 4 parts pyrite to 1 part marcasite would give no lines of marcasite at all.

Pyrite can scarcely originate from any other mineral than marcasite. The spectrogram indicates the presence of (Ag), Fe (and S), and the only minerals to be taken into consideration are then marcasite and pyrite, not taking into account sternbergite, argyropyrite, argentopyrite, and friseite. If the rather great anisotropism was due to the presence of these latter minerals, these same minerals would have indicated their presence also by their brown colour and their minimal hardness.

The graphic structure must have been produced by replacement, as marcasite does not incorporate silver in its crystalline structure, and thus cannot have been formed by the unmixing of a solid solution. In perfect accordance with this it is found that

the symplectite either is completely bedded in silver, or half of its circumference or more borders on silver, which will shoot long stolons into the marcasite. The percentage of silver seen in relation to that of marcasite being higher near the borders of the symplectite than nearer to the centre, this interpretation seems to be quite consistent.

Marcasite must be older than the silver by which it is replaced. It is also seen to be older than the pyrrhotite which is found as a seam on the border of marcasite and is sometimes seen to shoot into it. Whether marcasite is younger or older than the oldest sulphides is not known with certainty, but there seems to be some probability of its being younger.

As far as I have been able to find out, Kongsberg is the only locality at which marcasite undisputedly occurs as an older mineral in a hydrothermal vein, an observation which is quite inconsistent with the experimental data (1), which imply that marcasite is deposited from acid solutions at temperatures lower than about 400°. The experimental conclusions also imply that the higher the temperature, the higher must be the percentage of acid in the solutions in order to start the process of depositing marcasite. Only at ordinary temperature marcasite is produced from neutral solutions.

The solutions which have deposited marcasite in the veins under discussion have without doubt been alkaline, having been in equilibrium with calcite and various silicates in the veins and in the wall rocks. The temperature of formation cannot possibly have been lower than 200° C (this paper p. 33); to all probability the temperature of formation is found somewhere around 300° C.

Arsenopyrite.

Brünnich (5) mentions arsenopyrite from the prospect holes at Jonsknuten. Andresen (2) describes it from the mines at Sydvinoren and Rørdam remarks that it has been found in calcite veins in Ramvig's mine. In recent times neither I nor any one else has found this mineral and it is very probable that in the cases in which it is said to have been found, arsenides of Ni and Co (and Fe) have erroneously been taken to be arsenopyrite.

Diarsenides of Ni and Co, Rammelsbergite - Safflorite and Chloantite - Smaltite.¹

These minerals are very common in the veins, so common that only exceptionally a polished specimen of silver ore is made, in which these minerals are lacking. Still they occur only in small quantities (Fig. 8, p. 36), a fact which is due to the special mode of appearance of these minerals, as thin coatings around native silver. What I have here stated with regard to the frequency of occurrence is based on observations from those mines which are at present worked. According to R. Støren (70) the ore from the mine Samuel, where mining is now abandoned, should have contained no Co and Ni.

The diagnosis is based on the white colour of the minerals and on their hardness, which takes a middle position between the hardness of native silver and sphalerite on one side and that of pyrrhotite on the other. The fact that pyrrhotite is harder straightaway excludes the possibility of these minerals being either arseno-pyrite or cobaltite. Further the diagnosis is confirmed by a series of microchemical tests showing that the minerals consist of Ni, Co, Fe, and As. The fact that As is a main component puts out of the question the possibility of our having to deal with minerals of the linneite group, a possibility which is also weakened by the paragenetic conditions.

As to the relative hardnesses of the arsenides, these are not found to be in agreement with what has been arrived at by Schneiderhöhn — Ramdohr, in so far as in the specimen which was mentioned during the discussion of niccolite, in which all three arsenides were found together, chloantite - smaltite is found to be the hardest one, whereas niccolite and rammelsbergite - safflorite are between them approximately equally hard, niccolite probably just a little harder than rammelsbergite — safflorite.

All determinations with regard to the percentage of Ni and Co have been made from 13 specimens of silver or silver ore.

¹ In this chapter only these minerals have been called rammelsbergite - safflorite and chloantite - smaltite. Everywhere else they have been shortly denominated rammelsbergite and chloantite.

The determinations have been made by R. Støren, Holwech and E. Jensen. Ni and Co originating from Ni-Co-arsenides, the determinations will offer direct knowledge of the quantitative relations of Ni and Co in these minerals. The following molecular relations of Ni/Co have been found (where traces of Ni have been found, is given < 1): 0.5, < 1 , < 1 , 0.1, < 1 , 1.4, 0.6, 1.0, 0.8, 0.6, 0.9, 1.0. It appears that the proportions vary very much, but as a rule Co is present in larger quantities than is Ni.

In those cases where As has also been determined, the percentage is lower than demanded by the formulae of the Ni-Co-diarsenides. Instead of the value $x = 2$ in the formula $(\text{Ni, Co}) \text{As}_x$, the value of x is in these cases found to be about 1. This should rather indicate a mineral of the arsenopyrite group. This is on the other hand in disagreement with the above mentioned observations made with the reflection microscope.

On account of the observed deficiency of As it must be admitted that the diagnosis cannot be considered quite reliable, nor can it become so until we succeed in finding a specimen of the pure mineral for chemical analysis and for the production of Debye—Scherrer-diagram. I have not succeeded in picking out such a specimen, the mineral being found, as already mentioned, only as an extremely thin coating around native silver.

On account of the inconsiderable thickness of the coating of arsenide it is very difficult to observe whether the mineral is isotropic or anisotropic. In all probability it is as a rule isotropic, which implies that we have to deal with a mineral of the chloantite-smaltite series, a smaltite rich in Ni. However, I have also often observed distinct anisotropism, indicating the presence of safflorite. In each separate case it may be impossible to decide whether the mineral in question is chloantite-smaltite or rammelsbergite-safflorite.

As repeatedly mentioned these minerals appear as a thin coating round native silver. This coating usually is between 0.001 mm and 0.01 mm thick, but it may be thicker as well as thinner. It may be contiguous, or it may only partly cover the portion of native silver in question.

The paragenetic position of the minerals has been discussed on p. 117 ff, to which discussion I refer, as the space will not allow any extensive further enlargement on that point. Here I will just add a few concluding remarks. Not only Ni-Co-arsenides appear as coatings on native silver. Chalcopyrite too, and still more pyrrhotite, both exhibit structures of that kind. The conditions are best and easiest studied in the case of argentite. This mineral is found on native silver, as coatings which in the microscope give pictures of a striking similarity to those of the coatings of arsenides. There can be no doubt that this coating has been formed by a surface sulphuration of previously deposited silver. In ores from the zone of cementation pyrrargyrite may also be seen as coatings round native silver. In the cases of the following four minerals, i. e. chalcopyrite, pyrrhotite, argentite, and pyrrargyrite, nobody will certainly make any reservations in interpreting the structures as younger coatings on silver. Nobody will in these cases venture to maintain that native silver should have replaced the zonar structured mineral from within, leaving a thin crust. The fact that this is done in the case of the arsenides is probably due to two causes. The first one is that the arsenides are uncommonly often of a zonar structure, the various zones showing in fact a very varying resistiveness to chemical corrosion. The other reason is to be found in the experiments of Palmer and Bastin from 1913 and later (49, 50, 51) showing that the arsenides of Ni and Co will precipitate native silver from solutions containing silver ions. It was then close at hand to conclude, as was done by Bastin (3) in the case of Cobalt, that the intimate connection between the arsenides and native silver was to be explained by this process, arriving at the same time at a consistent explanation of the precipitation of native silver, which cannot be easily explained as having been crystallized from a saturated solution in the usual way. This view of the matter has been inherited by several ore geologists. Bastin himself has later left it, having been convinced by microscopical examinations that native silver must be older than the surrounding arsenides.

How then are the intimate relations between the arsenides and silver to be explained? What if the explanation is that

the chemical processes investigated by Palmer and Bastin are in reality chemical equilibria, according to which the equation

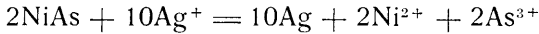

should in reality be written:

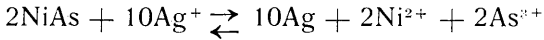

in accordance with the well known equilibrium:

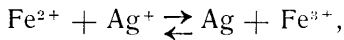

and that this equilibrium under the conditions under which the experiments of Palmer and Bastin were made, was pushed to the right, whereas under the chemical and physical conditions to which the ore-forming solutions were subjected during the formation of the arsenides, the equilibrium was pushed more to the left, or rather: was pushed still more to the left, thus causing the production of the Ni-Co-arsenides on the cost of silver, a process that might cause the formation of just such coatings as those with which we are dealing, and a process which is not unlike the process

native silver \rightarrow argentite.

Further investigations into the particulars of this process must be of very great interest.

In some few cases the coating shows a more complicated structure than that which has here been described. From the mine Christian VII at Helgevannet I have seen a coating of a zonal structure, the inner portion of the coating consisting of cloantite - smaltite, the outer one of rammelsbergite - safflorite (Pl. VII, Phot 13). The larger part of the coating consists of cloantite-smaltite. From the same locality are known double coatings separated by calcite (Pl. VII, Phot. 14, Pl. VIII, Phot. 15). This double coating must be supposed to have been formed by younger calcite having replaced a zone of the coating, that particular zone having not been in equilibrium with the solution. From this locality we have also beautiful specimens of the arsenides having by recrystallization got a separate crystal form towards the older silver (Pl. VIII, Phot. 15). If one by this is lead to believe the native silver to be younger than the arsenides, the macroscopic picture will soon lead one to the opposite con-

clusion, showing that the silver has been developed as thready silver (partly also in dendritic forms), and that these threads have a coating of arsenides. Further it will appear that on the threads of silver are found quite small crystals of Ni-Co-arsenides. On the whole the macroscopic picture will completely convince you that the silver cannot be the younger mineral.

I should like to stress anew before leaving this point, that it must be borne in mind that these double coatings are pure exceptions. As a rule we find single coatings, the thickness of which varies from 0.01 mm to 0.001 mm, consisting of either chloantite - smaltite or rammelsbergite - safflorite, without these minerals showing any indications of a crystal form of their own.

As mentioned during the discussion of niccolite, Ni-Co-arsenides also occur together with calcite, pyrrhotite, and chalcocopyrite as separate veins or as small veins in native silver (Pl. II, Phot. 3, Phot. 4). This too, indicates that the arsenides have been deposited later than native silver. +

Only seldom any of the arsenides are found as independent minerals without any direct contact with silver. During the discussion of niccolite was mentioned a specimen from Bratte-skjerpjet, 150 m level, an independent portion of which consisted of all the three occurring arsenides. In addition, from the mine Christian VII at Helgevannet, 150 m level, is known another independently occurring, quite small individual of rammelsbergite - safflorite.

As to the relative ages of the several arsenides, there are, as mentioned before, various indications to the effect of niccolite being the oldest one. As to the paragenetic relations of the two other arsenides it is, however, difficult to arrive at any reliable conclusion. The above mentioned zonal structured coating might indicate that rammelsbergite - safflorite is younger than chloantite - smaltite, the former mineral making up the outer part of the coating. Whenever, as is very seldom, I have found the two arsenides together, I have as a matter of fact usually been lead to think that they must have been formed contemporaneously, and it is only by chance that one or the other of these two minerals is formed.

Chlorargyrite.

According to old reports this mineral is said to have been found in the open at some mines. Brünnich (5) thus mentions that chlorargyrite was found together with native silver in the mine Haus Oldenburg.

Fluorite.

Fluorite is rather common and has been precipitated early in the period of mineralization as well as later (p. 117 ff.).

Fluorite may occur with many different colours from intense dark-purple, even almost black, to light-violet and quite colourless. Sometimes, but very seldom, is found a beautifully light-roseate fluorite or also an azure one. The green fluorites from Kongsberg occur primarily in sulphide-bearing quartz - breccia veins, some of which carry a considerable amount of green-coloured fluorite, whereas fluorite of this colour is seldom found in native silver - nickel-cobalt-arsenide veins.

Often we find colourless crystals with violet portions, the latter being either comparatively irregularly limited or they are limited by faces, very often (111). The violet portions sometimes have the form of thin flakes, or they are streaky. They are certainly not zones of growth.

The almost black, dark-violet fluorite is one of the oldest minerals and is found together with axinite and the oldest quartz, sometimes precipitated on the wall of the vein. The younger fluorite has weaker colours. Usually it is colourless and transparent or white.

From one of the mines at Helgevannet, Christian VII, is known filiform silver upon which are fixed crystals of rammelsbergite and small octahedrons of fluorite. N. Meidell (38) describes fluorite surrounding silver. (This might also have been a replacement phenomenon.)

The usual crystal form is the octahedron. At least 90 % of the crystals found are limited by the octahedron, which usually appears alone or if other faces are exhibited they are usually very incompletely developed. Twins after (111) are not rare. Crystals of fluorite from Kongsberg are famous

for their perfection and have earlier been described by several authors. Lévy (34, Taf. 11, Fig. 14) has pictured white, transparent crystals with violet spots. These crystals were taken from the mine Gottes Hülfe in der Noth. They have (100) and (110) and subordinate (311), (221), and (421). Zittel (82) mentions green, violet, and colourless crystals limited by (111) with or without (110), also (111) with (221), and further (100) with (110), (100) with (111), and (100) with (211). G. Rose (58) mentions the combination (111) (100) (311). Hessenberg (21a) describes: Transparent colourless crystal (110) (100) (311) with subordinate (11.5.3) and (10.4.3), colourless (*111*) (100) (311) (110), dark-violet with equal-sized (100) (11.5.3), bluish-grey (100) (311) (110) respectively (311) (100) (110), pallid indigotine (100) (110) (111), pallid blue (100) (111), pallid azure (110) (111) (100), (111) with indefinable (hhl), colourless (111) with (331) and a more plane (hhl), pallid green transparent (100) (110) (311) (11.5.3). Personally I have determined: light-violet (111) (551), colourless (111) (100) (110), colourless (111) (311) (100).

Quartz.

Quartz has been precipitated at all times. It appears as the oldest mineral precipitated directly on the wall of the vein, and also as one of the youngest as small transparent colourless crystals grown on other minerals. I have often seen that beautiful crystals in a vug have an inner coating of shiny black coal blend. The crystal has probably grown to a certain size, whereupon it has got a coating of coal blend and then it has again grown until it has reached its final size.

In harmony with the fact that quartz has been precipitated during the whole paragenesis we seldom find it resorbed or replaced by other minerals. However, I have seen quartz replaced by native silver. Usually quartz has not itself either replaced other minerals; it has been crystallized from the hot liquid solution, without other substances having at the same time been turned into solution.

The crystals have usually grown on the fundament after a plane which is almost vertical on the c-axis, the prism faces

being well developed and r-face (1011) predominating in relation to z-faces (0111). The s-face (1121) is rather common, whereas x (5161) is rare.

C. Bugge (12, p. 114) has described "coating quartzes" composed of calcedon-quartz combinations, and mentions that they are completely identical with the ones from Taunus described by H. Schneiderhöhn (63). However, it is possible that these forms belong to the sulphide-bearing quartz - breccia veins.

In thin sections we often find fine-grained quartz aggregates filling the intervals between older minerals. To all evidence they may have been produced by crystallization of a colloid.

The very youngest form is quartz in fissures in all other minerals and in cavities of various kinds, but it might be questioned whether this quartz should be taken to belong to the paragenesis. In the case of the implanted globules of quartz which are a curiosity sometimes found on the wall of the mines, this can definitely not be done.

Anatase.

Anatase is known only from a single specimen, labelled "Kristians søndre stoll. 1856". Together with anatase are found well crystallized albite and quartz and also chlorite (green ooze). Albite and quartz are older than anatase, chlorite younger. It appears from the label that anatase earlier erroneously was taken to be titanite.

Anatase occurs in unusually well developed crystals, up to $1\frac{1}{2}$ millimeter in size. The crystals are brown yellow and transparent. Its habit is best seen from the drawing (Fig. 24). Whereas anatase from other occurrences is usually acute-pyramidal with (111) as bearing, or obtuse pyramidal with (117) as bearing, or tabular with (001) as bearing, anatase from Kongsberg is obtuse pyramidal with (107) as bearing. This is, as far as I have been able to control, not the case with anatase from any other occurrence.

The faces found have been developed in this way: (107) bearing, (115) well developed, (101) and (111) not well developed, (001) developed only on one side of the measured crystal,

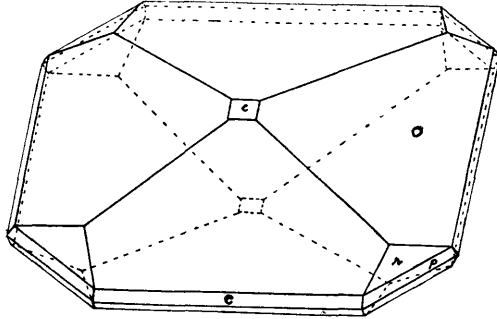

Fig. 24. Crystal of anatase. o (017), r (115), p (111), e (101), c (001).

and this face is so small that in the drawing it must necessarily be too large.

The axial ratio $a : c$ was calculated from the angles $(107) : (10\bar{7})$ and $(017) : (01\bar{7})$, these angles being best fitted for exact measurements. $a : c$ was found $= 1.7788$, whereas in the literature is given $= 1.7771$. The figure found by me is probably not reliable, being calculated from faces with high indices (107), whereas the axial ratio is in other cases probably calculated from (111). Experience shows that faces with high indices often have a defective structure. The measured angles do not always coincide with the ones found by theoretical calculations. Besides the crystal which in this case was measured is on the whole of a defective structure, the corresponding angles not being quite equal.

The specific gravity was found

$$\text{Sp.G.} = 3.884 \pm 0.003.$$

Calcite.

In the veins under discussion, calcite is many times as common as any other mineral (Fig. 7), and it has been precipitated from the beginning of the process of mineral production to the end of it. However, there must have been periods when calcite has not been in equilibrium with the ore-forming solutions, which may be gathered from the fact that we often find that older calcite has been resorbed to such an extent that only a small irregular remnant is left. Not seldom younger calcite has grown

upon this remnant of resorption and then with the same crystallographical orientation. Also during the precipitation of native silver, calcite has been resorbed and it is not seldom seen replaced by native silver. Later, however, the converse process has taken place, calcite having replaced native silver. On polished specimens may be seen how calcite has almost completely replaced the native silver within coatings of Ni-Co-arsenides, whereas the arsenides themselves have remained intact. Part of the silver has in this way again been turned into solution and has later been redeposited. At Kongsberg this process has not been very important. In the case of other silver deposits on the contrary, large parts of the precipitated silver has probably been dissolved and then redeposited, and thus this process has been of great importance in giving the ores their final structure. This has been more thoroughly dealt with on p. 127, see also the general map of paragenesis, p. 126.

E. Jensen (27) has made qualitative and quantitative chemical analyses of calcite from various veins in the Kongsberg formation and found that the percentage of iron is always low. Even iron-free calcite is found. However, some Mn is always present, the quantities E. Jensen found to vary from 0.42 % to 1.15 %, calculated as MnCO_3 . Yet the calcite is quite colourless and transparent.

By decomposing calcite in acids he was usually able to prove the presence of Cl^- - and SO_4^{2-} - ions and he holds the opinion, which is probably true, that these are due to sub-microscopical inclusions of the mother solution.

Personally I have with an X-ray vacuum spectrograph taken spectrograms of some specimens of calcite, and found Ca-lines, the lines of Fe and Mn. The relative intensities of the Fe- and Mn α -lines vary, but it may be said that on an average they are equally strong.

Uncommonly bright and pure cleavage sections of calcite ("Iceland spar") from the mine Mildigkeit Gottes, 124 m level, were decomposed in HCl and precipitated by NH_3 and $(\text{NH}_4)_2\text{S}$. I made an x-ray-spectrogram of the ignited precipitate, which made up 0.44 % of the weighed quantity of calcite. This spectrogram showed heavy lines of Ca (occluded), Fe, and some-

what weaker lines of Mn, and in addition weak lines of Y, Gd and Er, and as far as could be gathered also a very weak line of Dy.

The crystals of calcite show a multiplicity of forms. Th. Münster (44) in 1883 had the luck of finding an extraordinary fine material for the study of the crystals of calcite. The find was made in vugs in the mine Gottes Hülfe in der Noth, about 400 m level. This material enabled him to investigate how the habitus of the crystals were dependent on their age, and as a result of his examinations he divided calcite into 4 generations. The following faces are especially characteristic to these four types of crystals of calcite:

Calcite I ($10\bar{1}1$) as the only faces.

Calcite II ($10\bar{1}1$) mat, (0001) shiny.

Calcite III ($21\bar{3}1$), ($21\bar{3}4$), (8.8.16.3), $(02\bar{2}1)$.

Calcite IV ($10\bar{1}0$), $(01\bar{1}2)$.

Calcite I is the oldest one, calcite IV the youngest.

C. Morton (41) has measured a couple of crystals of calcite from Kongsberg. I reprint his illustrations as Fig. 25 and Fig. 26.

F. Sansoni (62) has found the following combinations of faces: $(10\bar{1}0)$, $(01\bar{1}2)$; $(10\bar{1}0)$, $(01\bar{1}2)$, (0001) ; $(10\bar{1}0)$, $(01\bar{1}2)$, $(44\bar{8}1)$, (4041) , $(43\bar{7}1)$, $(02\bar{2}1)$; $(21\bar{3}1)$; (9.5.14.4), (9.8.17.1), $(10\bar{1}0)$, $(10\bar{1}1)$, $(53\bar{8}2)$, (7.4.11.3). According to this author the lack of negative scalenohedrons should be characteristic to calcite from Kongsberg.

A special variety of calcite has at Kongsberg been called "slate-spar" ("skiferspat"). This consists of crystals of calcite, the base of which has been extremely developed making it measure e. g. 1 dm² whereas the hexagonal prisma is only 1 or 2 millimeters thick. The development may be still more extreme than this. The slates may either be parallel, often with quartz in between, or they may be arranged crossing and re-crossing each other making large cavities in the mineral aggregate. On the slates of slate-spar it is very common to find small shiny transparent crystals of quartz or small crystals of pyrite.

Usually the slates are stiff and inflexible, but they also occur undulating, often in several directions. The slates are then very thin, like thin paper. This undulating is scarcely due

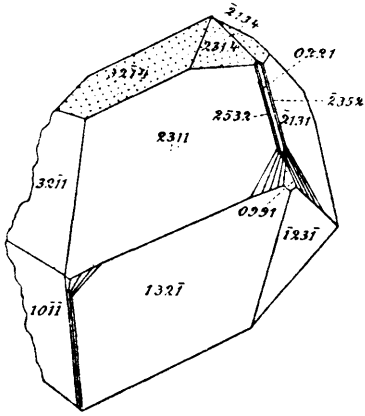

Fig. 25.

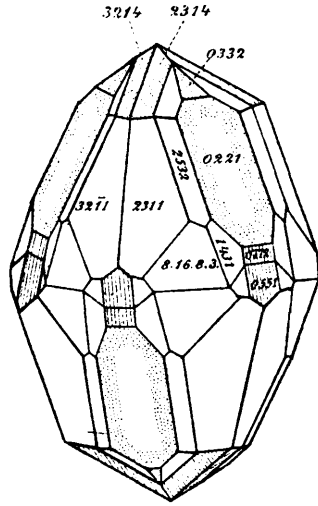

Fig. 26.

Fig. 25 and 26. Crystals of calcite. After C. Morton (41).

to tectonical influence but rather produced during the growth of the slates. These forms may be denominated the variety argentine. They appear very commonly in the mine Bratteskjerpet.

Slate-spar is one of the younger minerals of the paragenesis and it is often found together with zeolites. Now and then slate-spar occurs in special veins (probably representing younger fissures, which did not exist when the older minerals were precipitated). Chr. A. Münster (43, p. 64) believes a special vein-formation, slate-spar veins, to be younger than the silver-bearing veins. He maintains that the slate-spar veins never carry silver, which is very well in keeping with the theory that slate-spar is a younger mineral than native silver.

However, in agreement with C. Bugge (12) I cannot find any reason for regarding the slate-spar veins as a separate vein-formation. I am of the opinion that slate-spar is a member of the main paragenesis as a calcite-variety precipitated from the same solutions as the other minerals of this paragenesis.

As a rarity slate-spar is also found in the sulphide-bearing quartz - breccia veins. Sometimes it has been replaced by quartz.

Barite.

A superficial examination of a barite-bearing vein will easily lead to the conclusion that the vein does not carry barite at all, this mineral being easily mistaken for calcite. Because of this fact barite has been found to be somewhat more common than earlier supposed. As mentioned the peculiarity attached to the mode of appearance of barite is that this mineral has been especially enriched in some veins, in which it may be the dominating mineral, whereas in other veins it either appears very sparsely, or is completely lacking.

Barite usually appears with an independent crystal form against calcite, and where it occurs together with native silver, barite is always the older mineral. Barite is one of the very oldest minerals in the calcite - barite - fluorite - sulphide - native silver - Ni-Co-arsenide paragenesis. In harmony with this order of deposition C. Bugge (12) has found that veins rich in barite are often crossed by younger calcite veins without barite.

In a vein in the mine Bratteskerpet we find barite that is coloured red by a pigment. The colour is about the same as that of the red-coloured harmotomes, and the pigment may well be pryrargyrite. Often barite is coloured greyish-black due to interpositions of coal blend or related substances.

Crystals of barite are very rare. Ths. Münster found some in a vug in Gottes Hülfe in der Noth, 312 m level, in the year 1882 or 1883. In addition crystals of barite are known from Gottes Hülfe in der Noth, 168 m level, and about 90 m level. The crystals have later been examined by Th. Vogt (79), who has identified the following faces: c (001), b (010), a (100), β (310), m (110), n (210), x (130), o (011), $*w$ (2.0.13), w (106), l (104), g (103), $*z$ (5.0.13), d (102), u (101), z (111), $R?$ (223), r (112), f (113), q (114), v (115), P (116), y (112).

The crystals he classifies according to their habitus in the following types:

Type I. Gottes Hülfe in der Noth, 312 m level. Fig. 27.
Faces: m . d . z . o . b . c . a . r . f . β . n . x .

Type II. Gottes Hülfe in der Noth, 312 m level. Fig. 28
Faces: z . m . d . c . b .

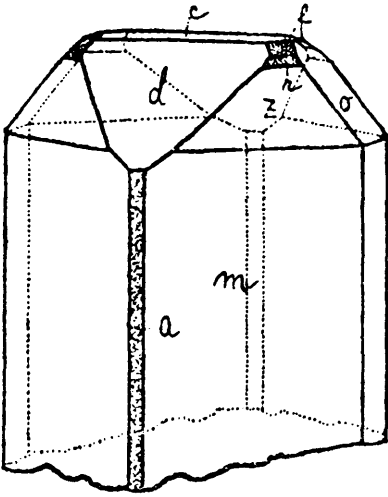

Fig. 27.

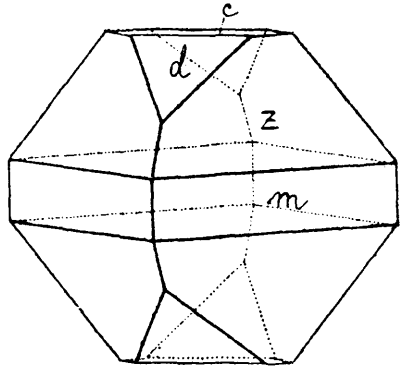

Fig. 28.

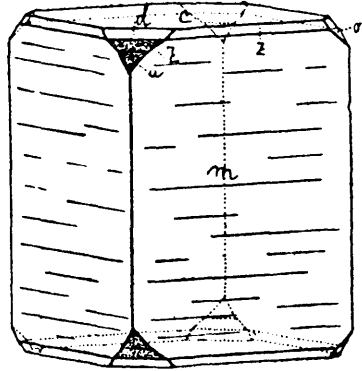

Fig. 29.

Fig. 27. Crystal of barite. Type I.
After Th. Vogt (79).

Fig. 28. Crystal of barite. Type II.
After Th. Vogt (79).

Fig. 29. Crystal of barite. Type III.
After Th. Vogt (79).

Fig. 30. Crystal of barite. Type IV.
After Th. Vogt (79).

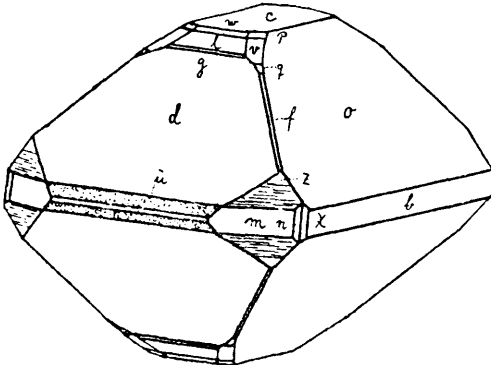

Fig. 30.

Type III. Gottes Hülfe in der Noth, 312 m level. Fig. 29. Faces: m. c. z. o. d. u. a. b. l.

Type IV. Gottes Hülfe in der Noth, 312 m level. Fig. 30. Faces: o. d. c. b. u. m. a. g. l. w. z. x. u. r. v. f. q. P. w. z.

Type V. Gottes Hülfe in der Noth, 168 m level. Tabular after base. Faces: c. d. o. m. u. l. a. b. z. r. q? g.

Type VI. Gottes Hülfe in der Noth, about 90 m level. Thick tabular after base to somewhat prismatic after b-axis. Dominant faces c. and d. Faces: c. d. o. m. u. l. z. y. a. b.

Erythrite.

Erythrite has been found in the following mines: Christian 6th at Vinoren, Fräulein Christiane, Juliane Maria, the mines at Jonsknuten, and the prospects at Kobbervolden. In recent times the mineral has been found by R. Støren in considerable quantities on the rock walls of the prospect Elgtjernhaug. Here the mineral was found as patchy coatings on vein rocks and in fissures of other minerals. In other places the mineral is said to have been found in aggregates of crystals with stellated structure.

Erythrite is found only in the open or very close to the surface. It is probably originated from arsenides of Co (and Ni) in the zone of oxidation. These arsenides being found only in connection with silver, it follows that erythrite occurs only in silver-bearing veins.

Epidote.

C. Bugge states (12, p. 150) that epidote is a comparatively common mineral. Personally I find that it is rather rare. I have not very often found it in the mines, and it is seen only in a few specimens. This disagreement may perhaps be due to the fact that at the time when C. Bugge examined the occurrence the mining was carried on in openings where today no mining is carried on.

On an epidote from a silver-bearing vein in the mine Samuel, the prehnite of which to a great extent dominated the gangue (p. 96) I measured:

$\beta = 1.760 \pm 0.003$ α colourless
 $\gamma = 1.773 \pm 0.003$ β green
2V — = approximately 75° γ green, somewhat lighter than β

The optical data correspond to an epidote with 33 mol % $\text{HCa}_2\text{Fe}_3\text{Si}_3\text{O}_{13}$.

I have also examined the refraction of an epidote from a pyrite - axinite - epidote paragenesis (p. 94). The specimen is taken from the mine Gottes Hülfe in der Noth.

$\beta = 1.762 \pm 0.002$
 $\gamma = 1.775 \pm 0.004$
2V — = approximately 70° — 80° .

These data give about the same composition of this epidote as of the one mentioned above. It is not well crystallized, and it is unusually light green. The pleochroism is not very prominent.

From the first mentioned specimen we gather that epidote is younger than prehnite, but it is probably older than apophyllite.

Axinite.

Axinite is rather a mineralogical rarity in the veins. It is nevertheless known from various mines. Most specimens come from the mine Gottes Hülfe in der Noth, but axinite has also been found in the mines Kongens grube, Morgenstjerne grube, Stadsmyr grube and Askebekk grube. In addition Hintze's Handbuch der Mineralogie mentions Rosengangen as a locality of axinite. For my investigations of axinite I chose a specimen from Gottes Hülfe in der Noth, 358 m level. The specimen was placed at my disposal by Universitetets Geologiske Museum (The Geological Museum of the University of Oslo). It displayed a richness in well developed crystals varying in size from 1 cm down to 1 millimeter. Some of the crystals exhibited dull and intransparent portions, but thin sections of a couple of the dullest portions showed no impurities from mineral inclusions. Probably the poor transparency is due to the fact that the crystals have been somewhat crushed through the mining or in other ways. All physical investigations have been made on the very

substance which was later analysed. The specific gravity was determined by means of a pycnometer with the following results:

$$1) \text{ Sp.G.} = 3.299. \quad 2) \text{ Sp.G.} = 3.291.$$

Because of the above mentioned mechanical crushing it must be supposed that these determinations are not quite reliable. As a check, I made a determination of the specific gravity by using heavy liquids, having for that purpose carefully selected 6 small faultless splinters of crystal. The determination gave Sp.G. = 3.300. This determination is probably the most exact one and I therefore give

$$\text{Sp.G.} = 3.299.$$

The refraction was determined by immersion liquids in Na-light:

$$\alpha_{\text{Na}} = 1.677 \pm 0.002$$

$$\beta_{\text{Na}} = 1.684 \pm 0.002$$

$$\gamma_{\text{Na}} = 1.690 \pm 0.002$$

The axial angle was determined with the universal stage in Na-light and found

$$2V \text{ — } = 76^\circ \pm 6^\circ.$$

The refractive indices:

$$\alpha_{\text{Na}} = 1.676$$

$$\beta_{\text{Na}} = 1.684$$

$$\gamma_{\text{Na}} = 1.689$$

give a calculated axial angle $2V \text{ — } = 76\frac{1}{2}^\circ$ and these data are within the border of errors of the measurements. In order to find the optical orientation of the axinite I picked out a small crystal the faces of which were identified with the goniometer (010), (350), and (110).

Crystallographical orientation after Peacock (53):

	Measured	Peacock
(010) : ($\bar{3}50$)	32° 59'	32° 59'
(010) : (110)	135° 31'	135° 25½'

The crystal was then imbedded in Canada balsam and mounted on an universal stage where it could be directly oriented.

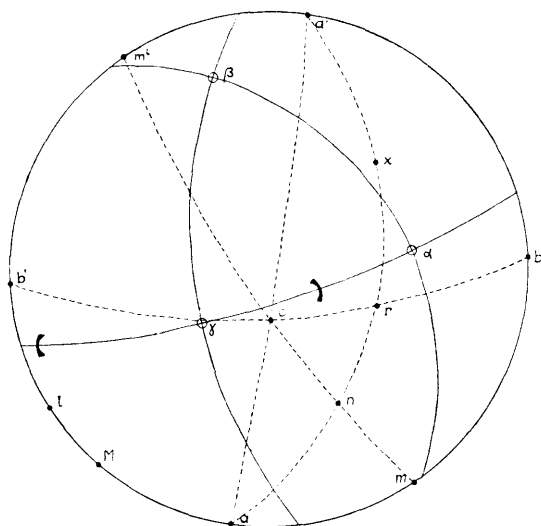

Fig. 31. Optic orientation of axinite.

The result of the examination will appear from the stereographic projection Fig. 31. To facilitate comparison the projection has been drawn in concordance with the method applied by Harada (21).

It will be noticed that the direction α does not by far so closely coincide with the normal to the x -plane as in the case of the axinite examined by V. M. Goldschmidt (19, p. 448) or in the case of the axinites examined by Harada (21). Nor is this to be expected, the axinite examined by V. M. Goldschmidt being a pure Mn-axinite from Årvold near Oslo, and the Japanese axinites as far as can be gathered from their respective specific gravities (3.305 and 3.312) being of quite a different composition from the one examined by me. One of the Japanese axinites has been analysed by Ford (17) and contains 77.3 mol.% Mn-axinite, whereas the axinite from Kongsberg, as may be gathered from the analyses below, contain only 37.3 mol.% Mn-axinite.

In order to secure exact and reliable results two analyses were made.

	I	II	Average
	%	%	%
SiO ₂	42.50	42.29	42.40
Al ₂ O ₃	18.25	18.20	18.22
Fe ₂ O ₃	0.64	0.41	0.53
FeO	5.74	5.92	5.83
MnO	4.41	4.43	4.42
MgO	0.71	0.96	0.83
CaO	19.51	19.93	19.72
Na ₂ O	0.14		0.14
K ₂ O	0.03		0.03
H ₂ O +	1.36	1.83	1.60
H ₂ O —	0.00	0.00	0.00
B ₂ O ₃	6.01	6.10	6.05
	6.03		99.77

Table 5. Analyses of axinite. Analyst Henrich Neumann.

The axinite consists of 48.5 mol.% Fe-axinite and 14.2 mol.% Mg-axinite.

Chemical composition	48.5% Fe-ax.	37.3% Mn-ax.	14.2% Mg-ax.
Indices of refraction ...	$\alpha = 1.676$	$\beta = 1.684$	$\gamma = 1.689$
Axial ang.	$2V = 76^\circ$		
Specific gravity	3.299		

Table 6. Chemical and physical data for axinite.

Crystals of axinite from Kongsberg have been measured by v. Rath (55) and Schrauf (65). Their illustration are given as Fig. 32 and Fig. 33.

In order to arrive at a general view of the axinite family I have made a calculation from those of the available analyses that seems to me to be tolerably reliable. These analyses I have entered together with that of the axinite from Kongsberg in a triangular diagram, in which the corners of the triangle represent the pure components of Fe-axinite, Mn-axinite and Mg-axinite. (Fig. 34.) The respective specific gravities I have put down at the representing points. Most of the analyses also indicates the presence of some Fe₂O₃. Fe³⁺ may well take the place of Al³⁺ in the diagram, and it would be possible to construct three ferri-axinites, making the number of components equal to six.

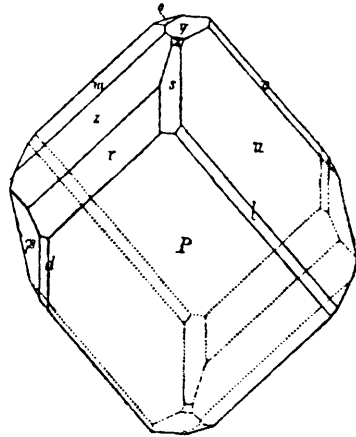

Fig. 32. Crystal of axinite. After v. Rath (55. Taf. 1. Fig. 19).

The contents of Fe_2O_3 is, however, on the whole not large. A striking feature is that in an ordinary composited axinite one half is made up of the ferro component, $\frac{1}{4}$ by the manganese component and $\frac{1}{4}$ by the magnesium component, and also that the magnesium component is the one which is usually found in the smallest quantity in axinite. The diagram also shows that it is not advisable to try to illustrate the variation of the physical properties of axinite in any bi-component system whatsoever, an effort which has been made by Gädeke (18) with a somewhat curious result. Besides it appears that the available data are not at all sufficient to enable us to draw curves with any degree of reliability.

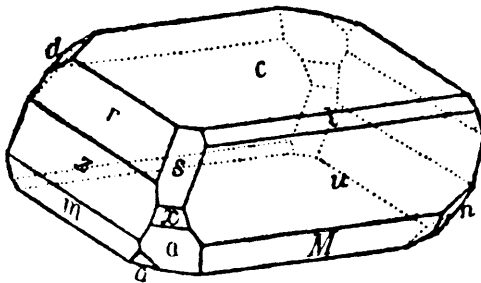

Fig. 33. Crystal of axinite. After Schrauf (65. Taf. 3. Fig. 16).

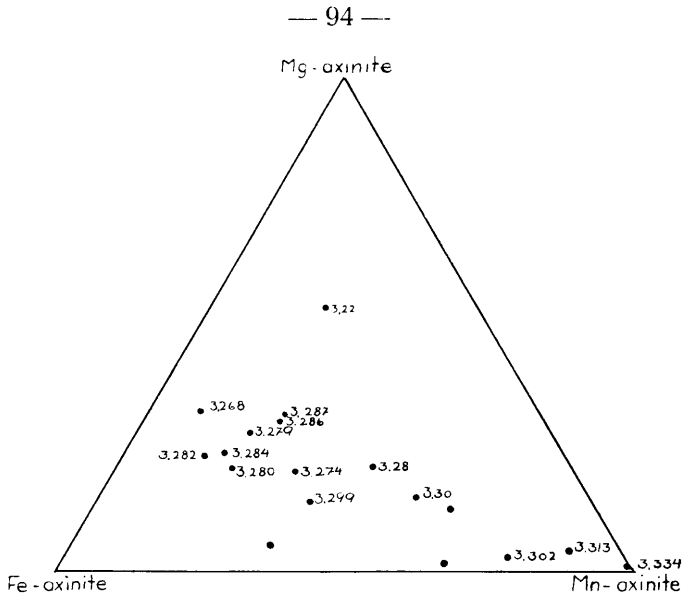

Fig. 34. Diagram showing chemical composition of axinites and corresponding specific gravities.

As to the paragenetical position of this mineral in the Kongsberg veins J. H. L. Vogt (78) maintains that axinite is one of the youngest minerals of the veins and that it has been formed contemporaneously with the zeolites. It cannot be doubted that this is wrong; on the contrary axinite is one of the oldest minerals. Only quartz that has been precipitated directly on the wall of a vein, and also fluorite of a dark violet colour, armenite, and bituminous calcite, may with certainty be reckoned older than axinite. To these may probably also be added coal blend and pyrrhotite.

Axinite often occurs in this way: Directly on the wall of the vein has been precipitated long, somewhat "dirty" crystals of quartz from base. Then axinite has been precipitated, and finally calcite, filling the fissure. The mineral has a characteristic way of occurrence in the following paragenesis: axinite, epidote, pyrite, fluorite, calcite and coal blend. I shall here give a description of a specimen of this type: It consists mainly of a compact axinite - felsite and bituminous calcite and displays the

typical porous appearance which is characteristic of pneumatolytic formations. In the pores we find well developed crystals of axinite and transparent calcite. The crystals of calcite can be traced with the same orientation into the bituminous calcite, and I conceive that they have been made by crystallization of the latter mineral. They have probably been formed contemporaneously with the axinite. Axinite is younger than the bituminous calcite. We find crystals of axinite on the walls of cavities in the latter, and the calcite is also cut through by small veins of axinite. The axinite - felsite looks like a changed piece of rock.

The genesis must have taken place in this way:

A calcite vein containing pieces of rock has been attacked by a very reactive B- and F-containing fluid, an aqueous solution, which has changed the pieces of rock into an axinite - felsite containing epidote, fluorite, and pyrite, whereas it has by corrosion created cavities in the calcite and filled these cavities with crystals of axinite, causing at the same time the recrystallization of the calcite.

The aluminium of the axinite must be supposed to have been extracted from the piece of rock, whereas B and Mn, and perhaps other components, belonged to the invading solutions. This view of the genesis of axinite has previously been maintained by Thomas van Hoerner (24).

It has already been mentioned that axinite suggests a comparatively high temperature of formation for the oldest minerals of the paragenesis (p. 33). The foundation of this contention is our knowledge of the genesis of axinite, according to which axinite may form in one of the following ways:

- 1) By contact metamorphism (by far the majority of the occurrences).
- 2) By precipitation from magmatic gasses in granite (Striegau Silesia; Baveno).
- 3) In hydrothermal veins (Berkutskaja in Ural, in a quartz vein; Andreasberg and Kongsberg in calcite - cobalt-nickel-arsenide - native silver veins).

To assume a temperature of formation of 400°—500° C for axinite in the Kongsberg veins therefore seems probable.

Prehnite.

Prehnite occurs both as well developed crystals and as the well known spherulitic forms. The spherulites may have a diameter of 2—3 centimeters, but usually they are considerably smaller; some of them have a greenish hue. The crystals are tabular after (001) and limited by (001) (00 $\bar{1}$) and the prisma (110).

Beautiful small crystals from the mine Gottes Hülfe in der Noth have these indices of refraction:

$$\alpha_{\text{Na}} = 1.651 \pm 0.001$$

$$\beta_{\text{Na}} = 1.620 \pm 0.002$$

The small indices show that prehnite must be poor in Fe^{3+} (18, p. 601). This is confirmed by the fact that the crystals are colourless.

C. Bugge (12) describes a silver-bearing vein in the mine Samuel where the gangue to a great extent consists of prehnite and not as usual calcite. In this vein, epidote as younger mineral is found together with prehnite.

Asbestos.

Asbestos is known from the Kongsberg formation from long ago, having then often been given names as mountain cork, mountain leather and mountain paper. It has as far as can be gathered usually been conceived as consisting of amphibole; this conception is, however, false. It consists of chrysotile, a fact that may be gathered from the refractive index:

$$n = 1.505$$

and from an optic spectrogram showing heavy lines of Mg and Si, and also lines of Fe and Al.

Asbestos is an aggregate of small needles and threads of chrysotile, these being arranged in every possible direction in a plane, thus forming foliaceous appearances. This at least holds true in the case of the varieties which have been denominated mountain leather and mountain paper. In the case of mountain cork the needles are as far as can be gathered arranged in all directions without any clear plane structure.

Asbestos has probably been produced by decomposition of the ferro-magnesian minerals of the surrounding rocks.

Deichman (15) mentions that amianthus was so common in a vein in the mine Samuel and that this vein was called "the wooden vein".

Apophyllite.

Apophyllite is not uncommon in the veins. Paragenetically it is connected with the zeolites and probably older than these. It is a rare thing to find several zeolites (apophyllite included) in the same specimen, and the relative ages of the various zeolites can therefore not easily be defined.

I determined the refraction of three different apophyllites, one from Christian's driftway, Myrgruben vein, 332 m level, one from the mine Gottes Hülfe in der Noth, 406 m level, and one especially stated to have been taken from a silver-bearing vein. For all three I found:

$$1.531 < \omega \text{ and } \epsilon < 1.538, \text{ uniaxial positive.}$$

Apophyllite is known only from vugs, where they have been developed in beautiful crystals of a size of up to a couple of centimeters. The crystals are tabular (601), and limited by (001), (100), (010), and (111). The planes are given according to their usual size, (001) being best developed and (111) usually showing the most incomplete development. In the case of some few crystals (001) is, however, replaced by (111).

Apophyllite is observed to be younger than quartz, albite, fluorite, calcite, prehnite, and epidote. Laumontite is younger.

Chlorite. Green Ooze.

Chlorite is a common mineral in the veins, but occurring as small interpositions or almost microscopical lines in the minerals of the veins, it is easily overlooked. Chlorite is best known as so-called green ooze, which is found in many pockets as a green powder covering all other minerals of the locality.

The material of the analyses below is just such dust collected from a series of pockets.

	%
SiO ₂	23.95
TiO ₂	tr.
Al ₂ O ₃	21.58
Fe ₂ O ₃	2.12
FeO	32.51
MnO	0.47
MgO	8.56
CaO	0.87
Na ₂ O	0.23
K ₂ O	0.03
H ₂ O	9.76
	100.08

Table 7. Analysis of green ooze. Analyst Lars Lund.

The analyses tolerably well correspond to a chlorite of this composition: antigorite + ferroantigorite : amesite + daphnite = 2 : 5, and Fe²⁺ : Mg²⁺ = 2 : 1, thus according to Winchel (81) an aphrosiderite. This result harmonizes with the observed index of refraction: $n \sim 1.654$. The birefringence is relatively large for a chlorite, the optical character being negative. The mineral is usually spherulitically developed.

In the mine Gottes Hülfe in der Noth, 564 meter level, there is a vein offering strikingly large quantities of sphalerite and galena. It has many vugs, in which are found as younger products, small green balls or perhaps small crystals of chlorite. The index of refraction is $n \sim 1.640$, and $2V = 10^\circ - 20^\circ$. The birefringence is very small and the mineral offers anomalous, blue shades of colour under crossed niccals.

In specimens from Elgtjernhaug mining claim may be seen calcite interwoven by dark dwindling veins of dark-green chlorite. The index of refraction is: $n = 1.640 - 1.650$.

In a silver-bearing vein in the mine Mildigkeit Gottes were 84 meters below level found small brown spherulites of chlorite. The indices of refraction of the spherulites lie between 1.635 and 1.645. The mineral has a marked cleavage and shows a brown colour parallel to the cleavage. Normal to the cleavage, the mineral is colourless. The pleochroism is very distinct. The mineral shows parallel extinction. When the spherulites are

crushed, small brown tables with hexagonal cross-sections are produced. The tables are too thin for their optical character to be determined. These tiny tables show no pleochroism. The sections of the spherulites are from 0.01 millimeter to 0.1 millimeter. They are built in such a way that the cleavage-planes radiate from a center. They occur together with young intergrowths of quartz and coal blend. Coal blend is younger than quartz, it being found as small balls on larger quartz crystals. The spherulites of chlorite are contemporaneous with or younger than coal blend.

As may be gathered, the optical data of this mineral might as well indicate biotite as chlorite, but considering the mode of appearance of the mineral, it must be taken for granted that we are here dealing with a chlorite of a brown colour, and not with biotite. It must be regretted that the spherulites are too small and too few in number to allow further investigations.

Wherever chlorite has been found it must be counted among the very youngest minerals; there are strong indications that chlorite is a secondary product.

Armenite.

Of this new mineral I have earlier given a more thorough-going description (45). It is a water-bearing barium - calcium - aluminosilicate, the formula of which is $\text{BaCa}_2(\text{Al}_2\text{Si}_3\text{O}_{10})_3\text{H}_2\text{O}$. It is known only from a single specimen from the mine Armen, from

	A	B
	%	%
SiO ₂	46.18	7690
Al ₂ O ₃	27.52	2692
BaO	12.37	829
SrO	0.04	4
CaO	9.99	1781
Na ₂ O	0.16	26
K ₂ O	0.13	14
H ₂ O +	3.41	1893
H ₂ O -	0.11	
	<u>99.91</u>	

Table 8. Analysis of armenite. A: weight percents. B: corresponding molecular proportions. Analyst Lars Lund.



Fig. 35. Armenite crystals. The two upper crystals have small axinites on the prism faces.

which it has got its name. Its appearance as oldest mineral together with axinite, pyrrhotite, quartz, and calcite indicates that it must be looked upon as an extremely rare member of the quartz - coal blend - fluorite - axinite - pyrite paragenesis (p. 117).

An analysis shows a composition in harmony with the formula above.

The mineral occurs in well developed, colourless to light green crystals with hexagonal habit (Fig. 35). Armenite is, however, not hexagonal, the pseudo-hexagonal crystals being penetration twins composed of rhombic individuals (Fig. 36). The indices of refraction are:

$$\alpha = 1.551 \pm 0.002$$

$$\beta = 1.559 \pm 0.002$$

$$\gamma = 1.562 \pm 0.002$$

and the optic angle $2V = 60^\circ \pm 2^\circ$.

The hardness is between 7 and 8 and the Sp. G. = 2.76.

Each rhombic individual possesses three tauto-zonal cleavage planes, one perfect and two distinct ones. The angle between them are all 120° , and the zone axis is parallel to the pseudo-hexagonal axis, corresponding to the optical direction α ; the best cleavage lies in the α - β -plane.

Armenite

⊥ α

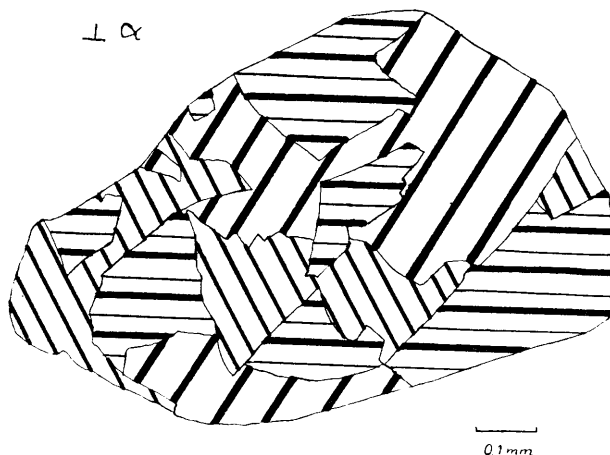

Fig. 36. Penetration twin of armenite, showing three individuals making an angle of 120° with each other.

The explanation to the above mentioned phenomena is probably that armenite has been formed as a hexagonal high-temperature modification which under decreasing temperature has been changed into a rhombic (?) low temperature modification.

The systematic position of armenite is still uncertain. The dehydration curve shows that it is not a zeolite (Fig. 37). On the contrary armenite shows strong resemblance to milarite. Both exhibit hexagonal habit and are composed of rhombic(?) segments. The data are as follows:

	Armenite	Milarite
Cryst. syst.	Rhomb. (?) and hex.	Rhomb. and hex.
Formula	$\text{BaCa}_2\text{Al}_6\text{Si}_9\text{O}_{30} \cdot 2\text{H}_2\text{O}$	$\text{KCa}_2\text{Be}_2\text{AlSi}_{12}\text{O}_{30} \frac{1}{2}\text{H}_2\text{O}$
n	1.56	1.53
H.	7.5	6
Sp. G.	2.76	2.6

Table 9. Chemical and physical data for armenite and milarite.

To show the supposed isomorphism we may write the formulas:

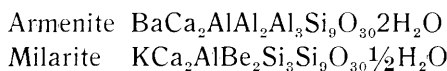

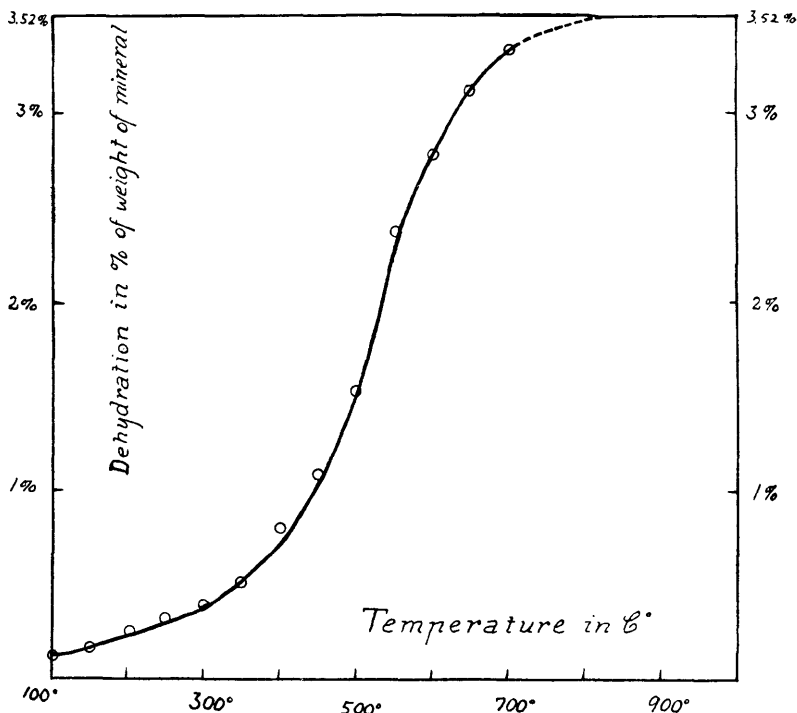

Fig. 37. Dehydration curve of armenite.

We see that in armenite the bivalent Ba (1.43 Å) replaces the univalent K (1.33 Å), and, in order to satisfy the valences, at the same time silica (0.39 Å) in the complex silicia-oxygen-anion of armenite is replaced by alumina (0.57 Å) and in milarite by beryllium (0.34 Å).

Hyalophane.

Hyalophane occurs rather seldom. According to C. Bugge (12, p.145) the mineral is more common in the main veins (p. 22) than in the ordinary veins. He mentions a vein in the mine Dergleichen where hyalophane occurs in such large quantities that in some places it is the dominating mineral of the vein.

Of this hyalophane he had the following analysis made:

	o/o
SiO ₂	57.98
Al ₂ O ₃	20.58
Fe ₂ O ₃	0.17
CaO	0.07
BaO	8.80
MgO	0.10
K ₂ O	11.05
Na ₂ O	1.32
	<hr/> 100.07 <hr/>

Table 10. Analysis of hyalophane. After C. Bugge.
Analyst O. Røer.

Recalculation of the analysis gives the following composition of hyalophane:

- Or 69.84 mol%
- Ce 17.11 -
- Ab 12.67 -
- An 0.38 -

That the composition of the feldspar varies from one grain to the other is shown by the determination of the specific gravity. Here I quote C. Bugge (12, p. 147): "A couple of grains showed Sp.G. 2.550; another couple of grains showed less than 2.560. Most showed more than 2.577. Only a few grains showed more than 2.670 and some few showed 2.701. With regard to specific gravity there thus seem to occur a series with values between 2.550 (specific gravity of adularia) and 2.701 (hyalophane).

The average index of refraction n_{β} of the various grains was found to vary between 1.525 and 1.528, which gives an average of 1.527."

From what is quoted above the average specific gravity may be fixed at about 2.62, and the physical data, index of refraction as well as specific gravity, then corresponds to a hyalophane with about 7 mol% celsian. I then do not take into consideration an admixture of albite (according to the analysis about 12½ %) which must be supposed not to influence the above mentioned physical constants very much owing to the great similarity of

the specific gravity and the indices of refraction of albite and adularia. The material used by C. Bugge for chemical analysis cannot have been identical with that used for examination of the physical constants. A hyalophane of the chemical composition indicated in the analysis should have $\text{Sp.G.} = 2.70$ and $n_{\beta} = 1.534$. The substance of analysis should thus correspond to the heaviest grains found by C. Bugge during his determination of specific gravity.

Personally I have examined the refraction of several crystals of hyalophane found in vugs. Using the indices of refraction it is possible approximately to calculate the quantity of celsian present in the mineral.

“Adularia”. Gottes Hülfe. $\alpha = 1.536 \pm 0.002$. $\beta = 1.540 \pm 0.002$. 25 mol% celsian.

“Adularia”. Gottes Hülfe. Main vein. 190 m level. W. C. Brögger 1878. $\alpha = 1.536 \pm 0.002$. $\beta = 1.540 \pm 0.002$. 25 mol% celsian.

Hyalophane. Mildigkeit Gottes. 124 m level. $\alpha = 1.534 \pm 0.002$. $\beta = 1.538 \pm 0.002$. $\text{Sp.G.} = 2.73$. 22 mol% celsian.

“Adularia”. Kongsberg. $\alpha = 1.532 \pm 0.002$. $\beta = 1.536 \pm 0.002$. 20 mol% celsian.

“Adularia”. Kongsberg. $\alpha = 1.531 \pm 0.002$. $\beta = 1.535 \pm 0.002$. 17 mol% celsian.

It thus appears that hyalophane from Kongsberg usually contains 20 mol% celsian or a little more.

It clearly appeared during the examinations that the composition was varying from grain to grain in accordance with the results arrived at by C. Bugge.

The habit of the crystals of the hyalophane is the simplest possible; they are limited by (110), (001), and $(\bar{1}01)$; they are short prismatic \perp c-axis and orthorhombic in aspect. Ths. Münster (44) mentions Carlsbad twins.

As to the age of the mineral this cannot be definitely determined, but it occurs very often together with zeolites and is in all probability a young product.

Albite.

Albite occurs with about the same frequency as hyalophane, perhaps it is a little more rare.

In vugs the mineral appears in small crystals the size of which are 0.1—0.5 cm. The crystals are limited by (010), (110), ($\bar{1}10$), (001), and ($\bar{1}0\bar{1}$). They are always twins after the albite law. As a rarity the albite law and the Carlsbad law appear together.

Ths. Münster has pointed to a rather curious phenomenon observed by him in Gottes Hülfe in der Noth; about 400 m level, i. e. the fact that albite crystals grown on older crystals of quartz cover only one side of the crystal of quartz, no albite being found on the other side of the crystal. He also points out that the side of the quartz crystal on which are grown crystals of albite will always turn upwards, the albite-free side always downwards. I have myself seen similar phenomena in the case of other minerals. The explanation must probably be that when the nucleus of a crystal has been formed in the solution, this nucleus is to begin with very small and light and will therefore swim in the solution like dust in the air. Later when it has grown larger, it will sink and by further growth become fixed to the fundament on which it has settled down. Naturally it will then not settle underneath a protruding crystal of quartz. It will settle on the top of it and later become fixed to it.

I have not been able to determine the paragenetical position of albite, but I have often seen the mineral growing directly on the wall of the vein together with quartz. Ths. Münster (44, p. 315) maintains to have seen very small crystals of axinite settled on the surface of albite. This should in addition to what has been mentioned above indicate a high age for albite. However the crystals of axinite were so small that Ths. Münster could evidently not be quite sure of a reliable diagnosis.

Indications are on the other hand also found to the effect of albite being paragenetically identical with the zeolites. This is, as has been mentioned, the case with hyalophane too.

Datolite.

When in 1939 I identified datolite in a specimen from Kongsberg an additional analogy with the deposits of Andreasberg, Harz, was found, datolite having for a long time been known from those deposits, but only now for the first time found at Kongsberg.

This mineral is extremely scarce in these veins. Hitherto it is known only from three specimens. One of them is in the collections of the Kongsberg Silver Works. This specimen carries silver together with datolite. In the remaining two specimens datolite is found together with axinite, the latter mineral being the older one.

In the specimen of silver ore, the locality of which is not known, the mineral occurs in well developed crystals, one large with a diameter of about 1 centimeter, and several smaller, the diameters of which are 1—2 millimeters.

The indices of refraction are:

$$\begin{aligned}\alpha_{\text{Na}} &= 1.622 \pm 0.001 \\ \beta_{\text{Na}} &= 1.649 \pm 0.002 \\ \gamma_{\text{Na}} &= 1.666 \pm 0.001 \\ 2V &= \text{approximately } 70^\circ\text{—}80^\circ\end{aligned}$$

The axial angle is probably somewhat varying from one grain to the other.

Winchell (81) gives for datolite:

$$\begin{aligned}\alpha &= 1.625 \\ \beta &= 1.653 \\ \gamma &= 1.670\end{aligned}$$

thus all indices 0.003—0.004 higher than found by me. Harada (21, p. 93), in complete agreement with Winchell, gives the following indices for Japanese datolites from Noborio and Hol-Kol:

$$\begin{aligned}\alpha_{\text{Na}} &= 1.626 \\ \gamma_{\text{Na}} &= 1.654 \\ \beta_{\text{Na}} &= 1.670\end{aligned}$$

It is not easy to see the reason for the lower indices of refraction of datolite from Kongsberg. However, replacement of Ca by Na seems possible. It is regrettable that datolite is not available in sufficient quantities for an analysis.

The specific gravity was determined and found:

$$\text{Sp.G.} = 2.997 \pm 0.003$$

In handbooks of Mineralogy the specific gravities of this mineral is given as 2.9—3.0. Harada has found 2.997 ± 0.002 (Noborio) and 2.995 ± 0.002 (Hol-Kol), that is to say the same specific gravities allowing some space for errors of measuring.

As to paragenesis, datolite is younger than axinite, but it has to all probability been precipitated in connection with the formation of axinite. It is probable that as long as aluminium is available (p. 95) axinite will form; when there is no aluminium left, Al-free datolite is formed. It is also possible that the paragenesis may depend on a fluctuating temperature, but to me it does not seem very likely that these minerals which are paragenetically thus closely connected should have been formed under decidedly different temperatures.

Natrolite.

Natrolite from Kongsberg is not found in any of the Norwegian collections, and personally I have never found this mineral in the mines. One specimen is said to exist in the collections of the University of Copenhagen. May be this is due to an error of diagnosis or to an interchange of specimens.

Laumontite.

Laumontite is not at all so very rare, and it is always somewhat decomposed because of dehydration, as is usually the case with this mineral. I examined the optical conditions of such a dehydrated laumontite, and found:

$$\alpha < 1.504, \beta \text{ and } \gamma \text{ both very near } 1.512.$$

$$2V \text{ — } = \text{approximately } 30^\circ\text{—}40^\circ.$$

Laumontite is in all probability the very youngest mineral of the paragenesis.

Stellerite.

This mineral, which is earlier known only from two occurrences, is in the Kongsberg veins known from several places. I first identified it in the mine Samuel grube, where it was found at a depth of about 50 m, just before this mine was abandoned. Stellerite from this mine has not developed crystal faces, but is found in the form of laminal mass, as far as can be ascertained in a vein of a thickness of 2—3 cm. The mass is laminal after (010), and thus parallel to the extraordinarily well developed cleavage.

Two analyses gave the following results:

	I	II	Average
	%	%	%
SiO ₂	59.19	59.26	59.23
Al ₂ O ₃	14.99	15.15	15.09
Fe ₂ O ₃	0.05	n. d.	n. d.
CaO	7.94	7.98	7.96
MgO	0.02	0.00	0.01
Na ₂ O	0.35	0.27	0.31
K ₂ O	0.00	0.00	0.00
Loss on ignition	18.24	18.20	18.22
Sum	<u>100.78</u>	<u>100.86</u>	<u>100.81</u>

Table 11. Analyses of stellerite. Analyst Henrich Neumann.

The only probable admixture of the material of the analyses must be calcite. However, treatment of the material with 2 n hydrochloric acid does not cause any development of gas. The figures of loss on ignition given in the table of analyses have been arrived at with a portion of 1/2 g. Morozewicz, who first described stellerite from the Commander Islands, gives somewhat varied determinations of the loss on ignition, 18.40 %, 18.41 %, 18.40 %, 18.57 %, 18.15 %. These variations he maintains depend on ignition of 18.42 % and 18.62 %. There seems to be some-ations of the loss on ignition. With a portion of 1 g. I found a loss on ignition of 18.42 % and 18.62 %. There seems to be something wrong with the determination of water. The following solution of the problem seems reasonable:

According to the data given by Morozewicz (20), stellerite loses about half of its water between 200° and 500°, (when the temperature is made to increase rapidly as done during a determination of loss on ignition, probably proportionally more); by this temperature water has a much larger power of decomposition than at 20°—100°. It is not improbable that at the moment when it leaves the mineral the superheated water disintegrates a portion of the mineral and removes it. In the table of analyses this loss in the mineral itself will be included in the loss on ignition (water). This will make the total too large, as the analyses are not made of the substance used for determination of the loss on ignition.

In order to examine the possibility of arriving at a result on this point I performed a determination of water after Penfield's method which allows a direct weighing of the water present. This determination gave 17.94 % water.

I give below the average of my two analyses with this determination of water, together with the analyses made by Morozewicz and the estimation of the composition according to the formula, respectively as IV, V and VI.

	IV	V	VI
	%	%	%
SiO ₂	59.23	59.23	59.67
Al ₂ O ₃	15.04	14.41	14.47
Fe ₂ O ₃	0.05	0.22	
CaO	7.96	8.23	7.96
Na ₂ O	0.31	traces	
H ₂ O	17.94	18.15	17.90
Total	100.53	100.24	100.00

Table 12. IV. Stellerite from Kongsberg. V. Stellerite from Commander Islands. VI. Estimated composition.

The total of the analyses IV not being satisfactory I made an additional main analysis, and the analyst of Universitetets Mineralogiske Institutt (The Mineralogical Institute of the University, Oslo). Civ. eng. Br. Bruun also had the kindness of making a check analysis.

	VII	VIII
	%	%
SiO ₂	59.23	59.09
Sesq.ox.	15.28	15.26
CaO.....	7.82	7.87

Table 13. Main analyses of stellerite for control. VII. Analysis of the author. VIII. Analysis by civil. eng. Br. Bruun.

As will be seen from table 13 the conformity is very satisfactory.

The indices of refraction were determined by the immersion method and found

$$\alpha = 1.482 \pm 0.002$$

$$\gamma = 1.493 \pm 0.002$$

The axial angle was determined with the universal stage and found 1) 2V — = 51°, 2) 2V — = 48°, consequently:

$$2V — = 49^\circ \pm 4^\circ$$

The specific gravity, determined by pycnometer and distilled water is 2.124.

For comparison I give in table 14 the constants found by Morozewicz (39), by Wheeler (80), and by myself.

	α	γ	2V —	Sp. G.
Morozewicz	1.484	1.495	43° 5	2.124
Wheeler ..	1.488	1.499	38°	
Neumann..	1.482	1.493	49°	2.124

Table 14. Physical constants of stellerite.

Most of the stilbites from Kongsberg are in all probability stellerites. A stellerite from Labrofoss mining claim gave

$$\alpha = 1.484 \pm 0.001$$

$$\gamma = 1.495 \pm 0.003$$

The contents of alkali of this stellerite was determined by mag. scient. Lars Lund and found

$$0.18 \% \text{ Na}_2\text{O}$$

$$0.17 \% \text{ K}_2\text{O}$$

The specific gravity was determined with heavy liquids and found Sp. G. = 2.127.

A grey, somewhat greenish, talc-like mass from Bratte-skjerpet mine, 62 m level, is composed of very small, partially spherulitic laminae and laminal aggregates with $n = 1.490$. The laminae are so small that their optical quality cannot be determined with exactness, but the mineral appears to be biaxial. This is probably a stellerite aggregate.

A stellerite from blygruben, Culmbach, Sandsvær, gave

$$\alpha = 1.487.$$

The determination of the optical orientation of the stellerite offered such great difficulties that I did not arrive at any definite result. The main difficulty consists first of all in the fact that it is impossible to produce orientated thin sections from this tender and cracky material. I therefore in making my investigations had to keep to powder preparations and the measurements which I made gave much varying results, e. g. a variation from 0° to 26° of $c : \alpha$. The two cleavage directions (100) and (001) should be perpendicular upon each other or near so. Yet I observed two evidently perfect cleavage-planes forming an acute angle; between crossed niccols the mineral will usually extinguish nearly parallel to one of them. Once I measured in a section two cleavages perpendicular on each other; the mineral extinguished almost exactly in the diagonal. I have concluded that these things depend on the variations in the percentage of water in the stellerite because of varying vapor pressure in the atmosphere. This causes variations in the position of the indicatrix and tensions is created in the mineral causing cleavages following planes which are normally not cleavage-planes. The process might also perhaps have been brought about by exchange of the water of the stellerite with cations of the substances contained in the liquids of immersion.

X-ray-investigations of the structure of stellerite have been made by Pabst (48) who claims to have proved that it is not as earlier supposed orthorhombic, but monoclinic, and that it should be regarded as the end member in the desmine series the formula of which is by him given like this:

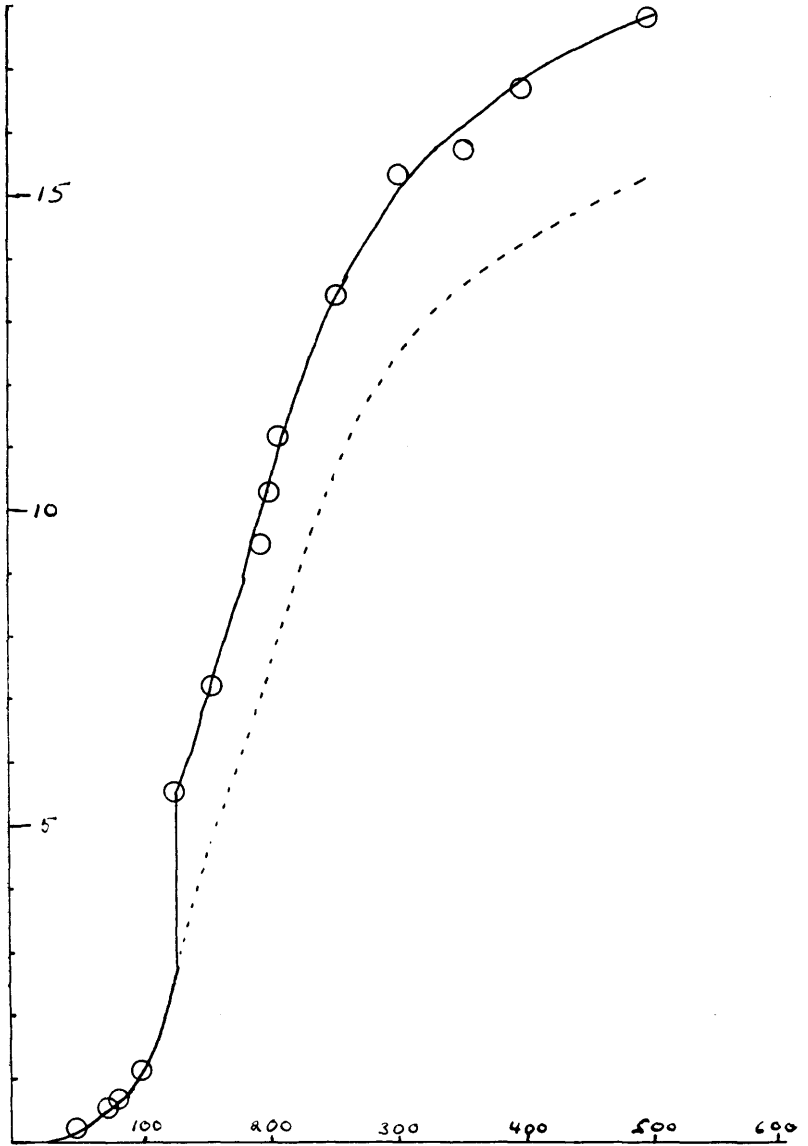
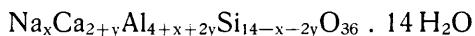

Fig. 38. Dehydration curve of stellerite. Broken line, dehydration curve for zeolitic water. Experimental data after Morozevicz (39).



where then in the case of stellerite both x and y should be given the value 0. This result seems to me to be right.

The dehydration curve has been determined by Morozewicz (39). The shape of the curve seems to suggest that stellerite has one molecule H_2O bound as crystal water, escaping at 125° , and the rest bound as zeolitic water. Also the data given by Morozewicz for the dehydration and for the variations in the optical constants of the mineral under varying temperatures agree with such a theory. The dehydration curve (Fig. 38) has been transcribed according to this hypothesis.

Stellerite has up to this day been regarded as a very rare mineral, and has hitherto been described only from two occurrences, i. e. by Morozewicz (39) who first described it from Copper Island, Commander Islands, and by Wheeler (80) from Alaska. Wheeler has suggested that the scarcity of the mineral depends on the fact that it cannot be formed except in an arctic climate or at least shows no constant composition except in an arctic climate. The error of this supposition appears from the fact that at Kongsberg it has been found 500 m below the level, and has in all probability originated from ascendent solutions. It might be suggested that the rareness of the stellerite is to a large extent due to inaccurate determination of the refractive indices of the stilbites. In this connection I should like to mention that Professor Barth has shown to me a mineral, found in a cavity in lava from Iceland, the appearance and optical data of which show complete accordance with stellerite.

Harmotome.

Harmotome is the most common zeolite at Kongsberg. It occurs both in the wellknown crossformed quaternions and as single individuals, attaining a size of 1 centimeter.

The indices of refraction and the axial angles are somewhat varying for the harmotomes which I have examined:

- | | |
|----------------------------|-------------------------------|
| 1) Harmotome. Kongsberg. | 2) Harmotome (red). The |
| $\alpha = 1.507 \pm 0.002$ | driftway of No. 9. Kongsberg. |
| $\beta = 1.506 \pm 0.002$ | $\alpha < 1.504$ |
| $\gamma = 1.510 \pm 0.002$ | $\beta > 1.504$ |

$2V +$ = approximately
 $70^\circ - 80^\circ$

$2V +$ = approximately 70°

3) Gottes Hülfe. 312 m level.
 $\alpha = 1.505 \pm 0.00$

4) The mine Anna Sofie.
 $\alpha < 1.504$
 $\beta = 1.504 \pm 0.001$

5) The mine Ny Segen Gottes.
 $\alpha < 1.504$
 $\beta > 1.504$

6) Harmotome. Kongsberg.
 $1.498 < \alpha$ and $\beta < 1.505$
 $2V +$ is rather small

7) (Stilbite): Kongsberg. P. Strøm.
 α and $\beta > 1.505$
 $\gamma = 1.513 \pm 0.002$

$2V +$ varies a little in the various grains from a little more than 0° to approximately 50° at most.

The specific gravity was determined for two specimens:

1) Sp.G. = 2.473 ± 0.003

7) Sp.G. = 2.400 ± 0.003

Sharp red colouring of harmotome is known from a few specimens. In a binocular magnifier it is distinctly seen that this is due to a pigmentation by a sharply red coloured, transparent, and very finely dispersed mineral. In the same specimens the calcite is also occasionally pigmented by the same red substance. It is not possible to identify this pigment in the microscope, but it is not far fetched to suggest ruby silver.

Coal Blend. (Anthracite, mineral coal.)

The international nomenclature does actually not offer any denomination for this mineral. At Kongsberg it has always been called coal blend (kullblende), and this denomination will be used in this paper. J. H. L. Vogt (78, p. 113) has called the mineral anthracite.

The occurrence of coal blend is tolerably common in the veins, and experience shows that the occurrence of coal blend often coincides with that of silver. Usually it occurs as spherical or almost globular forms, the size of these formations varying

from almost nothing to the size of an egg. The balls or spherules are often bright and shiny, but they may also be found dull. When they are cracked, the fracture is found to be conchoidal. The plane of fracture is usually shiny as a mirror. The hardness of the coal blend is between 3 and 4. Helland has found Sp.G. = 1.38. The specific gravity is to all probability variable.

Previously Helland has made an analysis of coal blend, the result of which is given here:

95.9 % C, 1.9 % H₂, 2.2 % O₂,

For control an analysis has been made for this paper:

90.5 % C, 2.2 % H₂, 0.5 % N, 0.4 % S, 5.5 % O₂, 0.9 % ashes.

Lars Lund analyst.

On the whole the analyses harmonizes quite well. Coal blend consists mainly of carbon, together with smaller quantities of oxygen, hydrogen, nitrogen, and sulphur. An x-ray spectrogram of the ashes from the analysis shows vanadium.

On polished sections coal blend shows a very great reflection pleochroism and effect of anisotropy. In polarised light the colour is leaden grey vertically on the cleavage-plane and greyish-brown parallel to it. Between crossed niccols the colour is light brown in diagonal position. The reflective capacity is low. J. Lietz (35) has made investigations on a specimen of coal blend consisting of an intergrowth of almost parallel stripes, where the individuals of the anisotropic minerals are oriented approximately vertically on each other. In the polished specimens in which I have seen coal blend, it has been built up from almost parallel, to all evidence leaf-shaped individuals. The sheets of parallel leaves are sometimes curved.

In the ore-microscope we find indications of the upbuilding of coal blend from small leaves of graphite, a peculiarity which has been earlier noted by J. Lietz (35). To verify this I have made a Debye-Scherrer diagram of the coal blend and also for comparison a diagram of graphite from Tvedestrand. The diagram of graphite gives clear and definite lines, whereas that of coal blend only gives a few indistinct lines which do not coincide with any of those of graphite.

Coal blend has probably a very complex composition. Besides graphite, it consists of carbon-hydrogen-oxygen-compounds rich in carbon, and of other organic compounds with nitrogen and sulphur.

That the lines of the diagram are so indefinite and vague is probably due to the fact that the substance which gives the lines is so greatly dispersed.

It is not improbable that coal blend has originally been a gel which has later to a large extent been crystallized. The globular structure of coal blend harmonizes quite well with such a proposition.

In this connection it might be mentioned that we often find small greyish-white pearl-like balls situated in open globular cavities in the coal blend. These small balls (measured across 1 millimeter or less) are spherulites of calcite. They are also found enclosed by the coal blend. Probably these spherulites have also been crystallized from a gel, or, put in a more correct way, they are concretions in a gel.

The spherules of coal blend appear in a variety of ways. In vugs they are found indiscriminately on various minerals. They are found along the cleavage-planes of calcite. They are also found on silver, often on the tip of a thread of silver.

Coal blend does not always appear with botryoidal structure. In several polished specimens I have found it with polygonal and sometimes acute-angled circumference. In one place it offered an almost triangular circumference in the middle of a portion of silver. Perhaps we here deal with remnants of replacement.

The age of coal blend and its place in the paragenesis are very difficult to decide because of the absence of crystallization. It seems to have been precipitated at various times. It is, however, usually very young.

Whether or not the so-called bitumen in calcite is of the same chemical composition as coal blend, is not known. It is perhaps not improbable. Besides much of what was believed to be bitumen in calcite, has been revealed as small interpositions of dark green chlorite.

	400-500°C			200°C	Super gene
Quartz.					
Pyrite					?
Calcite.					
Coalblend.					
Armenite.					
Fluorite					
Axinite.					
Barite					
Galena					?
Sphalerite.					
Chalcopyrite					
Sulphosalts of silver.					
Argentite					
Marcasite.					
Native silver					
Pyrrhotite.					
Nicolite.					
Diarsenides of Co, Ni, Fe.					
Zeolites					

Fig. 39. Paragenetic table.

Paragenetic Relations.

It is natural to make a division into three separate parageneses, an older quartz - coal blend - fluorite - axinite - pyrite paragenesis, a middle calcite - barite - fluorite - sulphide - silver - Ni-Co-arsenide paragenesis, and a younger calcite - zeolite paragenesis. (Fig. 39.) All these three parageneses have usually been precipitated in the same vein-fissure, but they are also found precipitated separately.

The Quartz - Coal Blend - Fluorite - Axinite - Pyrite Paragenesis.

As the oldest mineral in the veins we usually find quartz-crystals which have been precipitated directly on the walls of the vein, the c-axis of the crystals more or less vertically on the

wall. In some places we may observe that pyrite has first been precipitated on the wall of the vein, and later crystals of quartz. In other places crystals of pyrite have been precipitated on the prism faces of the quartz. On the latter we usually find precipitated small round balls of coal blend. Coal blend is also found in the quartz crystals as a pigment or as larger portions. In several cases we find an unbroken coating of coal blend in the quartz crystal, which, after some growth has got a covering of coal blend all over its surface, whereupon it has continued its growth. Coal blend is contemporaneous with or somewhat younger than quartz. In connection with the oldest quartz and younger than this we also find violet fluorite and axinite. These older minerals are usually finally bedded in calcite. This older calcite is in many cases bituminous. Axinite is sometimes younger than calcite. It has been supposed by J. H. L. Vogt (78) that axinite should be younger than silver and contemporaneous with the zeolites. All the specimens where silver and axinite occur together, show, however, that silver forms reentrant angles around the crystals of axinite, and also that silver has been precipitated in fissures in the crystals. Axinite being in several places found precipitated in connection with the oldest quartz, I find it likely that it belongs to the oldest part of the paragenesis, but it is possible that it ought to be placed as one of the oldest minerals of the calcite - barite - fluorite - sulphide - native silver - Ni-Co-arsenide paragenesis. At all events axinite is older than native silver. In addition to its occurrence together with the oldest quartz, axinite is also found in another characteristic way together with epidote, pyrite, fluorite, calcite, and coal blend (p. 94).

The Calcite - Barite - Fluorite - Sulphide - Silver - Ni-Co-Arsenide Paragenesis.

This paragenesis might perhaps be divided into three subdivisions: Oldest a calcite - barite - sphalerite - chalcopyrite - galena - marcasite -(pyrite) paragenesis; intermediate a younger fluorite - native silver paragenesis, and youngest a calcite-(pyrite) - pyrrhotite - chalcopyrite - Ni-Co-arsenide - sphalerite paragenesis. These subdivisions are, however, very closely

connected to each other and are best treated together. The first minerals to form were sphalerite, chalcopyrite, galena, and marcasite. I have not succeeded in arriving at any exact conclusions as to the mutual relation as to the age of these minerals, but generally speaking they seem to be contemporaneous. As already mentioned (this paper, p. 58) sphalerite usually contains well developed inclusions of chalcopyrite formed by unmixing. Contemporaneously with the sulphides calcite and barite were precipitated as vein minerals, the production of calcite being much larger than that of barite. The age of barite cannot be brought into relation with that of the sulphides, but it must be older than fluorite, and fluorite is in turn usually cut through by silver, mostly along the main cleavage of fluorite. However, the polished specimens and thin sections again and again show that silver and fluorite follow each other, from which fact may be concluded that silver and fluorite are paragenetic minerals and fluorite slightly older. The paragenetic relations of the above mentioned sulphides and silver is gathered from the fact that the sulphides are often intersected by small veins of silver, and that they are often replaced by silver. (Pl. I, Phot. 2.)

Younger than silver is pyrrhotite which is found as a coating round crystals and threads of silver. Sometimes it corrodes and penetrates into it like a cove or as a thin vein (Pl. IV, Phot. 7). Within the silver we often find small portions of pyrrhotite, reminding of replacement remnants. Probably they have a direct connection with the surrounding coating. This connection cannot be observed in the random section represented by the surface of the polished specimen. Together with pyrrhotite and paragenetic with this mineral we often find chalcopyrite (Pl. II, Phot. 3). Likewise paragenetic with pyrrhotite, but somewhat younger, arsenides of nickel and cobalt, niccolite, chloantite, and rammelsbergite have been precipitated (Pl. II, Phot. 3). These minerals occur in the well known way as thin crusts around threads of silver and crystals of silver. We often find contiguous crusts with irregular or approximately pentagonal or hexagonal borderings all covered by silver (Pl. VIII, Phot. 16, Pl. VII, Phot. 13). The question of the paragenetic relations between

these arsenides and silver has been discussed by many ore geologists, who have examined occurrences of this type. American ore geologists are mostly of the opinion that the arsenides are older than silver and have later been replaced by silver. On account of their zonal structure they have been replaced from within, a thin crust having then been left. (Lingren 36, Kidd and Haycock 31.) Bastin (4, p. 28) on the other hand has the opinion that the arsenides are younger than silver. German ore geologists such as Zückert (83), Keil (28), and Hoehne (23), hold silver to be older than the coating of arsenides, whereas Ramdohr (54) describes the Ni-Co-arsenides as older than silver. As regards the occurrences at Kongsberg, microscopical examinations of ore have previously brought Lietz to the conclusion that silver must be younger than the arsenides. Now, if zonal-structured crystals of Ni-Co-arsenides had a kernel which was not in chemical equilibrium with the silver-bearing solutions, but the edges of the crystals being in equilibrium, — a condition which would cause the replacement of the crystals of arsenide from within by silver —, then it would be natural to expect to find all stages of transition between not replaced crystals, partially replaced crystals and crystals of which only a thin crust on the surface would be left. However, this is not the case. We always find only a thin crust round silver. I know only a couple of exceptions from this rule. In one case (p. 62) a homogenous crystal of niccolite is surrounded by a thin coating of chloantite, in just the same way as is usual for silver. The other case shows a somewhat thicker coating of Ni-Co-arsenides. However, no zonal structure is to be observed. On the contrary the smaller patches of chloantite, rammelsbergite, and niccolite are quite irregularly distributed within the crystal, which has probably originally been homogenous. Thus only the former of these structures might have produced a portion of silver with a crust of chloantite by replacement of niccolite by silver. Having observed hundreds of examples of small grains of silver surrounded by the characteristic crust of chloantite, I have observed only this separate individual of niccolite, and not a single example of niccolite partially replaced by silver and surrounded by chloantite. Further stripings of calcite, pyrrhotite, chalcopyrite, and Ni-Co-

arsenides are often seen in silver in such a way as to indicate a younger age for these minerals than for silver. (Pl. II, Phot. 3.) The deciding proof is found in the fact that threads of silver have been coated by arsenides. (Pl. VIII, Phot. 16.) The thread form being quite specific to silver and other precious native metals, no other interpretation is possible than that silver must have been formed first and the Ni-Co-arsenides later. In this connection it has been suggested (35) that the threads of silver also were formed by replacement of the nucleus of chloantite which assumed a rod-like shape. Then it must be borne in mind that such crystals of chloantite have the shape of linear needles with well defined crystal outlines, whereas thready silver coated by arsenides has the same undulated and to some extent twisted forms as thready silver grown on argentite. It seems to me therefore that this explanation should be discarded.

The surrounding arsenides have by recrystallization developed a crystal habit of their own against silver. (Pl. VIII, Phot. 15.)

Still later than the arsenides, sphalerite together with calcite has been precipitated. As far as I have seen the youngest sphalerite never contains exsolution-inclusions of chalcopyrite. Sphalerite as well as calcite replaces silver.

There is a possibility of galena having also been precipitated at this time.

The Calcite - Zeolite Paragenesis.

In the concluding stages of the formation of the veins calcite, some quartz, and zeolites were precipitated. The relative ages of the various zeolites, is not known, each of them occurring alone and not together with their congeners. Only once two zeolites have been found together, viz: harmotome and laumontite. Laumontite is younger than harmotome and is probably the youngest mineral of the veins. As a rarity ruby silver was encountered in this paragenesis. We have reasons to believe that the red pigmentation of some harmotomes must be ruby silver, and ruby silver is also found below the surface of young calcites with hexagonal development. (See Fig. 21.) The ruby silver in calcite is pyrargyrite. Probably the solutions have to

a very small extent reacted on previously precipitated silver, and silver and antimony has again been precipitated as pyrrargyrite. It is possible that also inconsiderable quantities of argentite have been precipitated.

Finally may be mentioned that the occurrence of barite suggests the possibility of a special barite - galena - calcite paragenesis. Actually barite has been found only in comparatively few veins, but when this mineral occurs, it will usually occur in rather large quantities. In the mine Bratteskjerpet there is a vein the main mineral of which is barite, and in this vein galena occurs in by far larger quantities than usual. Barite veins have also been found at Vinoren, Blårud skjerp, and in several veins in the mine Mildigheit Gottes. In this last place barite is not the main mineral.

C. Bugge (12, p. 177—179) mentions that barite veins are often intercepted by veins of calcite, and he seems to be inclined to hold that they belong to a special formation of veins older than the calcite - native silver - Ni-Co-arsenide veins and younger than the sulphide-bearing quartz - breccia veins.

Supergene Ores and Minerals.

Of the minerals from the zone of oxydation only erythrite and chlorargyrite are known. Both of them are very rare. Chlorargyrite is actually known only from older descriptions. Of course some native silver may be of this origin, but is not necessarily so. Thus this zone is practically not found in connection with the Kongsberg occurrences. This is due to the fact that those oxydation minerals which were present before the glaci-ation of quaternary age, have been removed by the ice, and since that time new minerals have only to a very small extent been produced by oxydation of the original ones.

Neither is the zone of cementation in any degree prominent. However, in some places remnants of an older zone of cementation are found. Thus in the mine Mildigheit Gottes, 124 m level, an ore occurs containing large quantities of pyrrargyrite, a mineral which from larger depths is known more as a rarity. Here it will be seen (Pl. V, Phot. 10) that pyrrargyrite replaces native

silver and calcite, but not arsenides of Ni and Co. Together with pyrargyrite also occurs stephanite. — From the mine Christian VII at Helgevannet, 150 m level, is also known pyrargyrite together with stephanite in larger quantities than usual. Here pyrargyrite is also found as a thin coating on fissures in the rocks and in the vein mass, being a sure indication of a younger age. In former days when the mining was carried on nearer to the surface than nowadays, ruby silver ore was often mentioned in the reports, whereas now ore which contains any considerable quantities of pyrargyrite, is very rare. Argentite too is to all appearance more common at smaller depths than what is on an average found at larger depths, and from earlier periods are reported rich finds of arsenite ore near the surface. Together with argentite and sulphosalts of silver there occur in addition to native silver also quartz, calcite, and coal blend.

I have believed these ores to be supergene, but we cannot disregard the possibility of their having originated through a zonal structure of the original occurrences. If so, the ascending waters must be supposed to have deposited comparatively more argentite and sulphosalts of silver at some distance from the parental magma than nearer to it.

At all events these ores are comparatively rare. Usually the veins do not change their character against larger depths, thus containing the same minerals in approximately the same proportions at larger depths as near to the surface.

Comparison with Other Occurrences of the Native Silver - Cobalt - Nickel Ore Type.

Several comprehensive works have been written on this type of ore deposits. (See e. g. Bastin (4) and Schneiderhöhn (64, p. 605)). So far it is not necessary to point out that in spite of its relative scarcity this type of ore is widely scattered over the world and it seems in no way to be isolated within certain metallogenetic provinces. A table prepared by Bastin (4) showing the minerals appearing in the various occurrences throws very much light on the matter.

Some features characteristic of Kongsberg at once catch our interest, for example the lack of bismuth which is very common in most other occurrences. Bismuth is found in 19 out of the 33 occurrences mentioned in Bastin's table.

Native arsenic on the other hand is found as a rarity at Kongsberg (mentioned from 6 of the 33 occurrences in the above mentioned table).

Pyrrhotite which is very seldom found in this sort of veins, and is reported from only 4 of the 33 localities dealt with, is rather common in the district under discussion, and it is perhaps the most commonly occurring sulphide mineral pyrite not taken into account. Pyrrhotite, which is commonly supposed to have been produced under a comparatively high temperature, is younger than silver. (This paper p. 63.)

From 9 only of the 33 deposits mentioned by Bastin is reported fluorite, which is a very common vein mineral at Kongsberg. (This paper p. 79.) As I have previously mentioned (p. 119) silver and fluorite are often found together, and it is very close at hand to suppose that silver has been brought in by the F-bearing solutions as AgF . This has been previously noted by Ulrich (77) who has also in the laboratory performed the reaction $4\text{AgF} + 2\text{CaCO}_3 = 2\text{CaF}_2 + 4\text{Ag} + 2\text{CO}_2 + \text{O}_2$, a reaction which in his opinion to a large extent must be due to the precipitation of native silver in the veins at Kongsberg. There is, however, so great internal similarity between all occurrences of the nickel-cobalt - native silver type that an analogous history of formation seems reasonable. Thus a feature from one special occurrence must not be made the foundation of an explanation of the mechanism of deposition. All known occurrences must be taken into consideration. The lack of fluorite in most occurrences of this type can evidently not be explained if the above mentioned reaction should be the key to the right understanding of the precipitation of native silver. I suppose it is right therefore to regard the paragenesis of fluorite and native silver as more or less fortuitous.

Boron minerals are extremely rare in this group of occurrences. Only from two localities is tourmaline reported, i. e. from Dobschau in Hungary and Zinkwand - Voettern in the

Eastern Alps. From Kongsberg is known axinite and datolite, both of them are very rare. Axinite and datolite are also reported from Andreasberg in Harz. The literature dealing with this occurrence is comparatively scanty, and the occurrence has not been examined with the ore-microscope. It seems to have a quite striking similarity to the occurrence at Kongsberg.

The occurrence at Kongsberg shows a very important difference from other occurrences in so far as, with the exception of the very rare native arsenic and coal blend, concretionary structures are lacking, these structures being very characteristic to other calcite - native silver - nickel-cobalt-arsenide veins. I have not succeeded in finding in the available literature calculations of the depths at which these veins have been precipitated, but we are justified in believing that the lack of concretionary structures depends on the fact that the veins at Kongsberg have been precipitated at comparatively large depths. (The high age of the Great Bear Lake occurrence, about 1350 million years (37), indicates that this occurrence must have been precipitated at large depth, and here concretionary structures are exceptionally common.) The only precipitations at Kongsberg which might from their appearance have been originally precipitated as gels, are certain fine-grained specimens of quartz (p. 81). As to the ore minerals there are no indications of such a mode of precipitation. (On the other hand concretionary structures are known from pyrite from a sulphide-bearing quartz - breccia vein at Eiker.)

Much uncertainty is attached to the question of the paragenetic relations of the minerals of these deposits. This is to some extent due to the fact that some research workers have not been able to find deciding evidences bearing on the paragenetic conditions. Besides there is much disagreement between the various geologists who have examined the same occurrences. When, in spite of this, I have in Fig. 40 tried to view all those occurrences which have been most thoroughly examined from one common point of view and have to that effect made a general table of paragenesis for the calcite - native silver - pitchblende - native bismuth - nickel-cobalt-arsenide - sulphide veins, this is of course done with certain reservations. I must at once

	1	2	3	4	5	6	7
<i>Sulphides</i>	▲ ○ • +				○		▲ ○ ⊕ □ ×
<i>Native silver</i>		▲ ○ ⊕ □ × +				⊕ ×	
<i>Bismuth</i>			▲ ⊕ □				
<i>Pitch-blende</i>				▲ □ ×			
<i>Arsenides</i>		(⊕) (+)	(⊕) (□)		▲ ○ ⊕ □ × +	(×)	

- *Kongsberg.*
- ⊕ *Cobalt.*
- *Erzgebirge.*
- × *Bergfreiheit.*
- *Islet mine.*
- + *Wickenburg.*
- ▲ *Hypothetic ideal deposit with completely developed paragenesis and without redeposition of the minerals.*

Fig. 40. General table of paragenesis.

premise that in the case of the Silver Islet occurrences I adhere to the conception of Parsons and Thomson (52), whereas Chadbourn (14) has by later investigations arrived at a different result, which in my opinion probably is wrong. Ramdohr (54) has examined a small occurrence near Darmstadt, and has arrived at results which do not fit in on the table in Fig. 40. However, if the coatings of arsenides are taken to be younger than silver, we shall here have the same paragenetic conditions as elsewhere. Kidd and Haycock (31) have in the case of the Great Bear Lake occurrences arrived at results which fit very badly in the general table of paragenesis.

The table, Fig. 40, should be rather instructive and needs no thoroughgoing comments. However, I want to point out verbally as well that there is some variation as to the time of the

deposition of arsenides, and also as regards the time of the conclusion of their deposition.

The youngest sulphides of the Kongsberg occurrence are sometimes older than the arsenides. This is evidently not the case in the other occurrences. It may be due to the fact that the younger sulphide which was first deposited at Kongsberg is pyrrhotite (Fig. 39) which occurs in relatively large quantities (Fig. 8), whereas this mineral, as mentioned above, is either not found at all in the other occurrences, or it is of no great importance.

Keil (28) has maintained that the youngest generation of silver (in Fig. 40 marked with the number 6) might be redeposited silver and not brought in from external sources, and then deposited. I fully share his conception on this point. I do not doubt that in the case of the Kongsberg occurrences there is found native silver which has been deposited later than may be concluded from the tables of paragenesis Fig. 39 and Fig. 40. Probably even as late as at the time of precipitation of the zeolites, older silver has been corroded and redeposited in another place. However, these phenomena being of quite inconsiderable importance in the veins at Kongsberg, I have, in order not to disturb the total aspect even found it right to disregard them completely when making the tables of paragenesis. In the case of some few other occurrences this late corrosion and redeposition of silver has been by far more important.

Finally I ought to mention that those minerals and groups of minerals which are in Fig. 40 marked by the numbers 1—7, are not equally closely paragenetically connected. The oldest sulphides and the later groups are in all probability not very intimately connected, whereas native silver, native bismuth, and pitchblende are in some cases quite cogenetic. It may be clearly gathered from the table Fig. 40 that the arsenides must be included in this family. On the contrary it is rather astonishing to find the younger sulphides connected with the paragenesis to such an extent as that which is indicated by the conditions at Kongsberg, so much the more so, since the silver - arsenide - paragenesis has been considered almost sulphide-free. It has, however, been known previously that arsenides and *sulpho*-arsenides were cogenetical in the veins of the Cobalt district.

Acknowledgements.

My teachers, Professor Tom F. W. Barth and Professor V. M. Goldschmidt, have, during my stay at the University as well as later, stimulated me to undertake these investigations and have through conversations and discussions contributed largely towards making my studies interesting and attractive. They have put the facilities of Universitetets Mineralogiske Institutt and Universitetets Geologiske Museum fully at my disposal.

Professor Th. Vogt, Director of the Geological Institute of Norges Tekniske Høyskole, Trondheim, has allowed me to work at the institute for a shorter period, and Dr. Harald Bjørlykke of the same institution has instructed me in the use of X-ray-spectrographs.

The Kongsberg Silver Works, first under the management of Director E. A. Dalset and later under that of Director B. K. Sherdahl, has advanced and supported my work as often as an opportunity has been offered. I should particularly mention the manager of the smelting-works, R. Støren, M. E., who has in many ways been of invaluable help to me, first of all by allowing me to draw upon his rich experiences from a life-long interest in the Kongsberg minerals and their occurrence. The Silver Works has also to some extent supported my work economically.

The economical aid has, however, primarily been given by Bjørums Fond, Sulitjelmafondet, and Børresens og Hybinettes Fond. Of deciding importance to the accomplishment of the undertaking has been the purchase of a first-rate metallographic microscope for The Geological Survey of Norway.

Mag. sc. L. Lund and Mr. B. Bruun, civ. eng., have performed chemical analysis, Dr. I. Oftedal has taken optical spectrograms, and cand. mag. H. Major and cand. real. T. Rosenqvist have taken Debye-Scherrer-diagrams. Mr. Anker Iversen

of Norges Tekniske Høyskole has with his acknowledged ability made the polished specimens, and Mr. Chr. Jørgensen, civ. eng., Mr. R. Kongsgård, Miss U. Hofseth, Miss B. Mauritz, and Mrs. M. Sommerfeldt have assisted in producing the necessary photographs and drawings.

Last, but not least, lektor, cand. philol. Olav Løkse has undertaken the thankless task of translating the manuscript from Norwegian into English.

Without all kindness and aid from the institutions and persons here mentioned, this paper should not have appeared, and I therefore offer my most sincere and grateful thanks to them all.

Literature.

1. Allen, E. T., Crenshaw, I. L., Johnston, L., and E. S. Larsen. Die mineralischen Eisensulfide. *Zeitschr. anorg. Chemie.* **76**, p. 201. (1912.)
2. Andresen, C. F. Om Gangformationer ved Kongsberg. *Forhandlinger ved de skandinaviske naturforskeres 10de møte 1868*, p. 558.
3. Bastin, Edson S. Significant mineralogical relations in silver ores of Cobalt, Ontario. *Econ. Geol.* XII, p. 219. (1917.)
4. — The nickel-cobalt-native silver ore type. *Econ. Geol.* XXXIV, p. 1. (1939.)
5. Brünnich, M. L. *Forsøg til Mineralogie for Norge*. Prisskrift, Trondhjem. 1777.
6. Bugge, Arne. *Geologi og grubedrift ved Kongsberg Sølvverk*. Tidsskr. f. Bergvæsen. Febr. 1914.
7. — *Kongsberg ertsdistrikt*. N. G. U. nr. 98. (1922.)
8. — *Oversikt over inndelingen av det sydnorske grunnfjell, samt om fahlbåndene i Kongsberg ertsdistrikt*. N. G. U. nr. 133. (1929.)
9. — *Gammel og ny geologi ved Kongsberg Sølvverk*. *Norsk Geol. Tidsskr.* **12**. (1932.)
10. — *Sølvforekomsten ved Kongsberg*. *Naturen.* **58**, p. 193. (1934.)
11. — *Flesberg og Eiker, beskrivelse til de geologiske gradavdelingskarter F 35 ø og F 35 v*. N. G. U. nr. 143. (1937.)
12. Bugge, Carl. *Kongsbergfeltets geologi*. N. G. U. nr. 82. (1917.)
13. — *Sølvet på Kongsberg*. *Tidsskr. f. Kjemi og Bergvesen.* **11**, p. 33. (1931.)

14. Chadbourn, Charles Henry. Paragenesis of the ores of the Silver Islet mine, Thunder Bay region, Lake Superior. *Econ Geol.* XVIII, p. 77. (1923.)
15. Deichman. Efterretning om nogle Stenarter og Ertzer. *Kgl. Vid. Selsk. Skr.* 11te Del. (1777.)
16. Durocher, J. M. Observation sur les gites métallifères de la Suède, de la Norvège et de la Finlande. *Ann. d. Min.* 4. 15., p. 351. (1849.)
17. Ford, W. E. Ueber die chemische Zusammensetzung des Axinites. *Zeitschr. f. Krist.* 38, p. 82. (1904.)
18. Gädeke, Rudolf. De gesetzmäßigen Zusammenhänge und Anomalien der Vesuviangruppe. *Chemie d. Erde.* 11, p. 592. (1937.)
19. Goldschmidt, V. M. Die Kontaktmetamorphose im Kristianiagebiet. *Vidensk.selsk. skr. Kristiania. I. Mat.-naturv. Kl. No. 11.* (1911.)
20. — Kristallchemie. *Handwörterbuch der Naturwissenschaften.* Jena 1934.
21. Harada, Zyunpei. Zur Kenntnis der japanischen Bormineralien. (Studien über japanischen Bormineralien IX.) *Journal of the Faculty of Science, Hokkaidô Imperial University. Series IV, vol. V, No. 1.*
- 21a. Hessenberg. *Min. Not.* 5, p. 2. (1863.) *Abh. Senckbg.* 4, p.182. (1863.)
22. Hiortdahl, Th. Om Underberget ved Kongsberg, og om guldets forekomst sammesteds. *Nyt Magazin f. Naturvid.* XVI, p. 37. (1869.)
23. Hoehne, Karl. Über einige Arsen-Nickel-Kobalt-Silber-Wismut- und Uranerzführende Kalkspatgänge der Grube Bergfreiheit zu Oberschmiedeberg im Riesengebirge. *Chemie d. Erde.* 10, p. 432. (1936.)
24. v. Hoerner, Thomas. Über die Axinitvorkommnisse von Thum in Sachsen und die Bedingungen der Axinitbildung überhaupt. *Zeitschr. d. deutsch. Geol. Gesellsch.* 62, p. 1. (1910.)
25. Holter, A. Uttalelser om sølvforekomstene på Kongsberg. *Tidsskr. f. Kjemi og Bergvesen.* 11, p. 2. (1931.)
26. — Sølvforekomster på Kongsberg. *Tidsskr. f. Kjemi og Bergvesen.* 11, p. 93. (1931.)
27. Jensen, Einar. Sølv på Kongsberg, om de kjemiske prosesser ved dets utfelling og om trådsølvdannelsen. *Norsk Geol. Tidsskr.* 19, p. 1. (1939.)
28. Keil, Karl. Beiträge zur Kenntniß der Kobalt-Nickel-Wismut-Silber-Erzgängen. *Diss. d. Sächs. Bergakad. Freiberg.* 1929.
29. — Über die Ursachen der charakteristischen Paragenesenbildung von gediegen Silber und gediegen Wismut mit den

- Kobalt - Silber - Eisen - Arseniden auf den Gängen der Kobalt-Nickel - Wismut - Silber - Erzformation im sächsisch-böhmischen Erzgebirge und dem Cobalt-Distrikt. Neues Jahrb. f. Min. **66**. B.—B. A., p. 407. (1933.)
30. Kennigott. Sitzb. Ak. Wien. **9**, p. 575. (1852.)
31. Kidd, D F., and M. H. Haycock. Mineragraphy of the ores of Great Bear Lake. Bull. Geol. Soc. Amer. **46**, p. 879. (1935.)
32. Kjerulf, Th. Komisjonsinnstilling. 10de juli 1865.
33. Langberg, Chr. H. Om Ertsleiestederne paa Kongsberg. Nyt Magazin f. Naturvid. VII, 2. (1863.)
34. Lévy. Coll. Heuland. **1**, p. 158. (1834.)
35. Lietz, Joachim. Mikroskopische und chemische Untersuchungen an Kongsberger Silbererzen. Zeitschr. f. ang. Min. **2**, p. 65. (1939.)
36. Lindgren, Waldemar. Mineral Deposits. Third ed. New York 1928.
37. Marble, John Putnam. A further study on the age of Great Bear Lake pitchblende. Am. min. **22**, p. 564. (1937.)
38. Mejdell, N. Om den sandsynlige Dannelsesmaade af de Kongsbergske sølvførende Gange. Nyt Magazin f. Naturvid. VIII, 2. (1855.)
39. Morozevicz, J. Über Stellerit, ein neues zeolithmineral. Bull. int. de l'Acad. d. sci. d. Cracovie. Cl. d. sci. math. et nat. 1909. P. 344.
40. Morton, Carl. Stephanit från Kongsberg. Kgl. Vetensk.-Akad. Förh. 1884. **2**, p. 99.
41. — Några goniometriska bestämningar å kalkspat från Arendal, Kongsberg, Utø og Bamble. Kgl. Vetensk.-Akad. Förh. 1884. **8**, p. 65.
42. Münster, Chr. A. Kongsbergsølvets sammensetning og en sekundær-proces ved dets dannelse. Nyt Magazin f. Naturvid. **30**, p. 266. (1891.)
43. — Kongsberg Ertsdistrikt. Vidensk.selsk. skr. Christiania. I. Mat.-naturv. Kl. No. 1. 1894.
44. Münster, Ths. Bemerkninger om Kongsbergminerallerne. Nyt Magazin f. Naturvid. **27**, p. 309. (1883.)
45. Neumann, Henrich. Armenite, a water-bearing barium-calcium-alumosilicate. Norsk Geol. Tidsskr. **21**, p. 19. (1941.)
46. Niggli, Paul. Versuch einer natürlichen Klassifikation der im weiteren Sinne magmatischen Erzlagerstätten. Abh. prakt. Geol. **1**. (1925.)
47. Oftedal, Ivar. Untersuchungen über die Nebenbestandteile von Erzmineralien Norwegischer Zinkblendeführender Vorkommen. Vidensk.selsk. skr. Oslo. I. Mat.-naturv. Kl. No. 8. (1940.)
48. Pabst, Adolf. The relation of stellerite and epidemine to stilbite. Min. Magazine. XXV, p. 271. (1939.)

49. Palmer, Chase and Edson S. Bastin. Metallic minerals as precipitants of silver and gold. *Econ. Geol.* VIII, p. 140. (1913.)
50. Palmer, Chase. Tetranickeltriarsenide, its capacity as silver precipitant. *Econ. Geol.* IX, p. 664. (1914.)
51. — Diarsenides as silver precipitants. *Econ. Geol.* XII, p. 233. (1917.)
52. Parsons, A. L. and E. Thomson. *Contrib. to Canad. Min.* 1921.
53. Peacock, M. A. On the crystallography of axinite and the normal setting of triclinic crystals. *Am. Min.* 22, p. 588. (1937.)
54. Ramdohr, Paul. Der Silberkobalterzgang mit Kupfererzen von Niederramstadt bei Darmstadt. *Notizbl. Hess. Geol. Landesanst.* 5, p. 164. (1924.)
55. v. Rath. *Pogg. Ann.* 1866, p. 128.
56. — Aus Norwegen. *Neues Jahrb.* 1869.
57. Rose, G. *Pogg. Ann.* 23, p. 201. (1831.)
58. — *Zeitschr. d. Deutsch. geol. Ges.* 14, p. 239. (1862.)
59. Sadebeck, Alexander. Ueber die Krystallformen der Blende. *Zeitschr. d. Deutsch. geol. Ges.* 21, p. 620. (1869.)
60. — Ueber die Krystalltektonik des Silbers. *Tschm. Mitt.* 1, p. 293. (1878.)
61. — Ueber geneigtflächige Hemiëdri. *Zeitschr. d. Deutsch. geol. Ges.* 30, p. 567. (1878.)
62. Sansoni, F. Beitrag zur Kenntniss der Krystallformen des Kalkspates. *Giorn. d. min., crist. e petr. d. Sansoni.* 1, p. 129. (1890.)
63. Schneiderhöhn, Hans. Pseudomorphe Quarzgänge und Kappenquarze von Usingen und Niederhausen im Taunus. *Neues Jahrb. f. Min.* 2. (1912.)
64. — *Lehrbuch der Erzlagerstättenkunde.* B. I.
65. Schrauf. *Wien. Sitzb.* 1870. 62. (2.)
66. Short, M. N. Microscopic determination of the ore minerals. *U. S. G. S. Bulletin* 825. (1931.)
67. Streng, A. Mineralogische Mittheilungen über die Erze von Chanarcillo in Nordchile. *Neues Jahr. f. Min.* 1878, p. 897.
68. Strunz, Hugo. *Mineralogische Tabellen.* Lpz. 1941.
69. Støren, R. Kongsberg Sølvverks stufsamling som grunnlag for studiet av sølvforekomstenes dannelsehistorie. *Tidsskr. f. Kjemi og Bergvesen.* 11, p. 16. (1931.)
70. — Kobolt-nikkel-gedigentsølv-ganger i Kongsbergdistriktet. *Tidsskr. f. Kjemi og Bergvesen* 11, p. 95. (1931.)
71. — Om sølvproduksjonen i Kongsbergfeltets gruber fra 1623 til 1933. Oslo 1934.
72. — Om Kongsberg Sølvverks mineralsamlings betydning som materiale for studiet av sølvforekomstene. *Tidsskr. f. Kjemi og Bergvesen.* 15, p. 28. (1935.)
73. — Om platekrystaller av gedigent sølv m. m. *Tidsskr. f. Kjemi og Bergvesen.* 15, p. 124. (1935.)

74. Sundt, L. Nogle bemerkninger om Kongsbergs gange og gangminerale. *Archiv f. Math. og Naturvid.* XXVIII, nr. 3. (1907.)
75. Tronstad, L. Bemærkninger til spørgsmålet om Kongsbergsølvets genesis fra elektrokjemisk standpunkt. *Tidsskr. f. Kjemi og Bergvesen.* **12**, p. 15 og p. 28. (1932.)
76. Tronstad, L. und T. Høverstad. Über das Becquerel-Phänomen und die Genesis des metallischen Silbers im Kongsberggebiet. *Norske Vidensk.selsk. skr.* 1933. No. 9.
77. Ulrich, Friedrich. *Věda Přírodní VII*, p. 238. (1926.)
78. Vogt, J. H. L. Über die Bildung des gediegenen Silbers, besonders des Kongsberger Silbers, durch Secundärprocesse aus Silberglanz und anderen Silbererzen, und ein Versuch zur Erklärung der Edelheit der Kongsberger Gänge an den Fahlbandkreuzen. *Zeitschr. f. prakt. Geol.* 1899, p. 113 und p. 177.
79. Vogt, Th. Schwerspat aus norwegischen Vorkommen. *Norsk Geol. Tidsskr.* **1**, nr. 9. (1908.)
80. Wheeler, E. P. Stellerite from near Juneau, Alaska. *Am. Min.* **12**, p. 360. (1927.)
81. Winchell, A. N. *Elements of optical Mineralogy. Part II.* Third ed. New York 1933.
82. Zittel. *Neues Jahrb.* 1860, p. 793.
83. Zücker, R. Die Paragenesen von gediegen Silber und Wismut mit den Kobalt-Nickelkiesen und der Uranpechblende zu St. Joachimstal in Böhmen. *Mitt. Abt. f. Gesteins-etc. Untersuch. Preuss. Geol. Landesanst.* **1**, p. 69. (1926.)

Printed April 18th 1944.



Phot. 1. Pyrite (white) showing euhedral crystals with reference to quartz (dark grey), and quartz with reference to native silver (strongly tarnished). 100 \times .
Mine Bratteskjerpet. 112 m level.

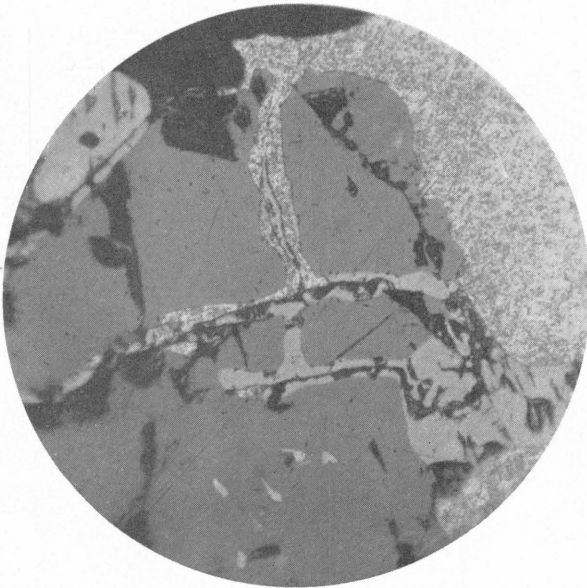

Phot. 2. Pyrrhotite (light grey) and native silver (tarnished) as veins in sphalerite (dark grey) with spots of chalcopyrite (very light grey).
300 \times . Juuls mine.

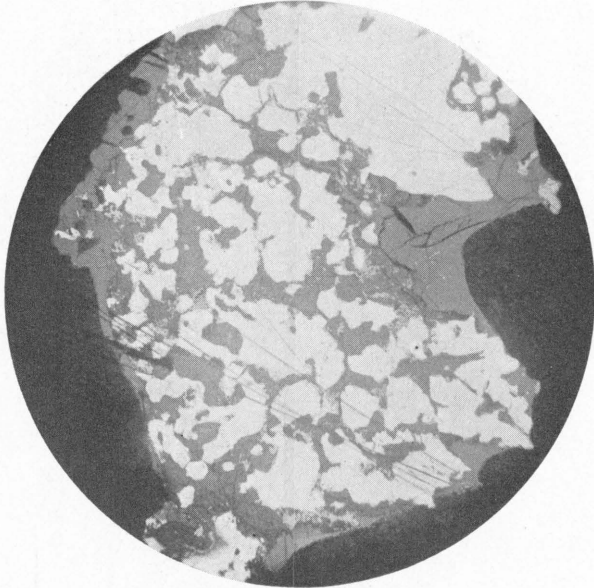

Phot. 3. Veinlets of calcite, pyrrhotite, chalcopyrite, niccolite and diarsenides of Co and Ni (light grey) in native silver (white). Quartz (grey). Grey as well as black bakelite near the borders. 7 ×. Mine Haus Sachsen. 480 m level.

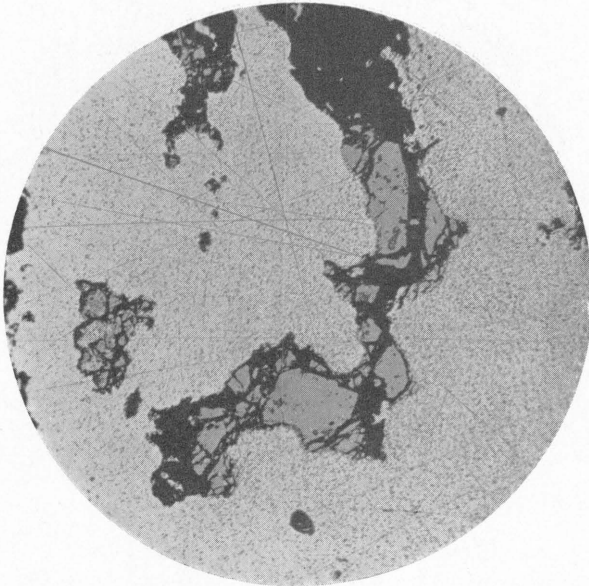

Phot. 4. Veinlet of calcite (black), niccolite (dark grey) and chloantite (light grey) in native silver (white, tarnished). Same paragenesis as Phot. 3, but without pyrrhotite and chalcopyrite. 50 ×. Mine Gottes Hülfe in der Noth.

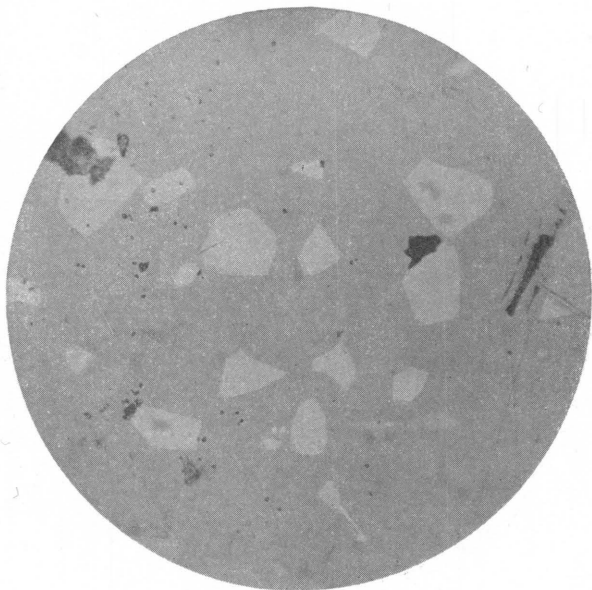

Phot. 5. Arsenic (grey) with spots of antimony (light grey). 300 \times .
Kongsberg, mine unknown.

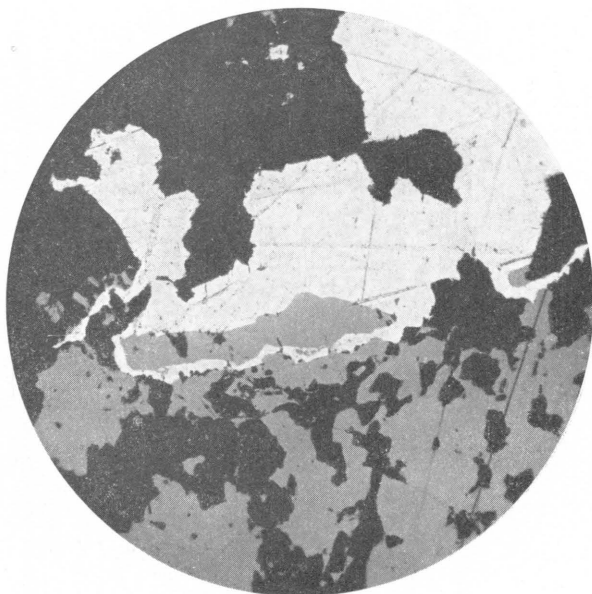

Phot. 6. Young sphalerite (grey) replaces native silver (white) within a coating
of chloantite (light grey). Calcite (black). 100 \times . Mine Haus Sachsen.
480 m level.

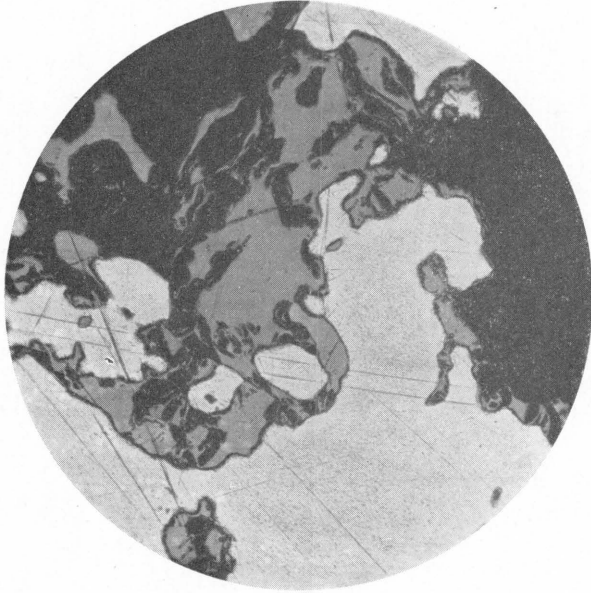

Phot. 7. Pyrrhotite (grey) replaces native silver (light grey). Gangue (black).
50 \times . Mine Kongens grube. 520 m level.

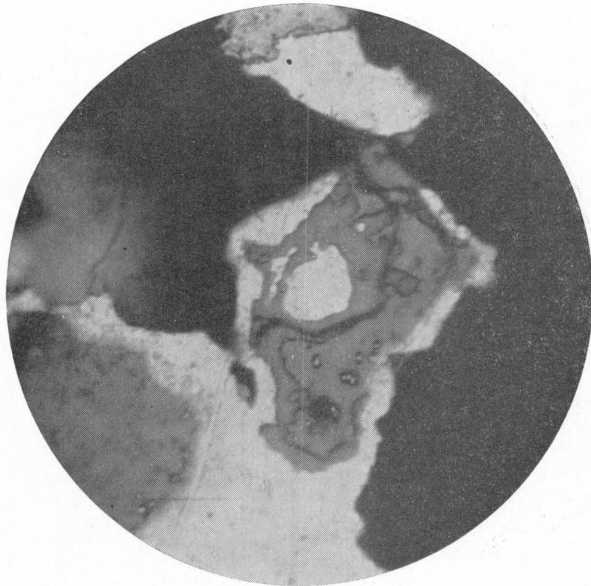

Phot. 8. Stephanite (grey) around ruby silver (a little more light grey) within
native silver (white). Chloantite (light grey) and calcite (black). 1100 \times
Mine Gottes Hülfe in der Noth. 624 m level.

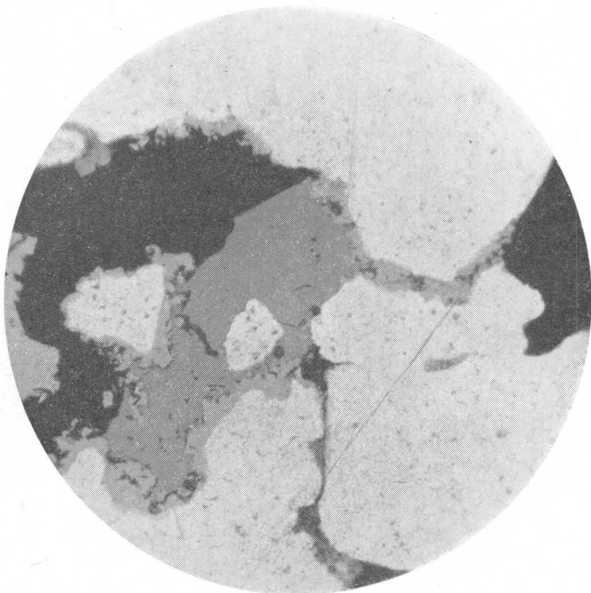

Phot. 9. Stephanite (grey) with a replacement remnant of native silver (white) within a coating of chloantite (light grey). Gangue (black), and argentite (dark grey) near the border. 300 \times . Mine Christian VII. 150 m level.



Phot. 10. Ruby silver (grey) replaces native silver (white) and calcite (black), but not chloantite (white, relief). 50 \times . Mine Mildigkeit Gottes. 124 m level.

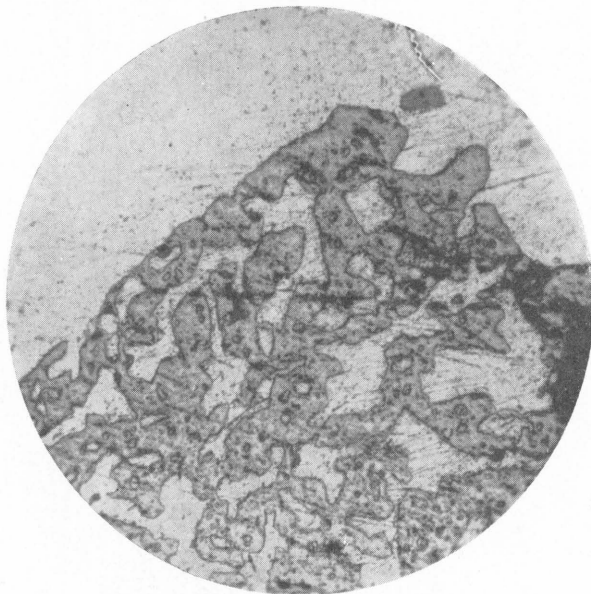

Phot. 11. Native silver (white) replaces marcasite partly rendered to pyrite (grey). 300 \times . Mine Kongens grube. 520 m level.

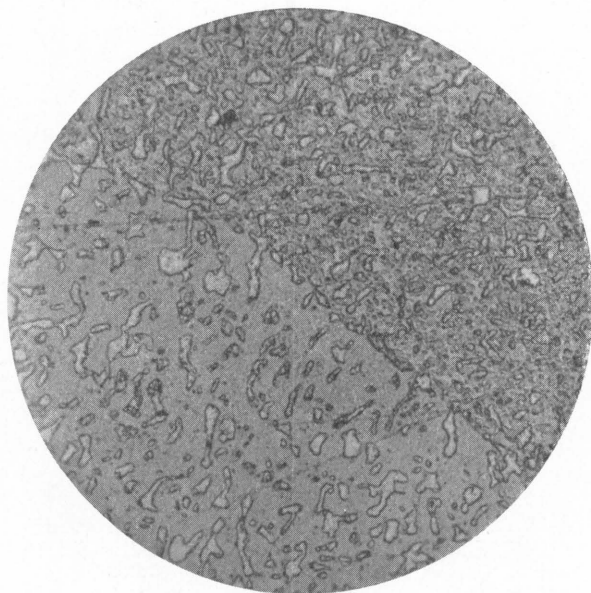

Phot. 12. Native silver (white) replaces marcasite which is partly rendered to pyrite (grey). Note border between twin crystals of marcasite. 200 \times . Mine Kongens grube. 520 m level.

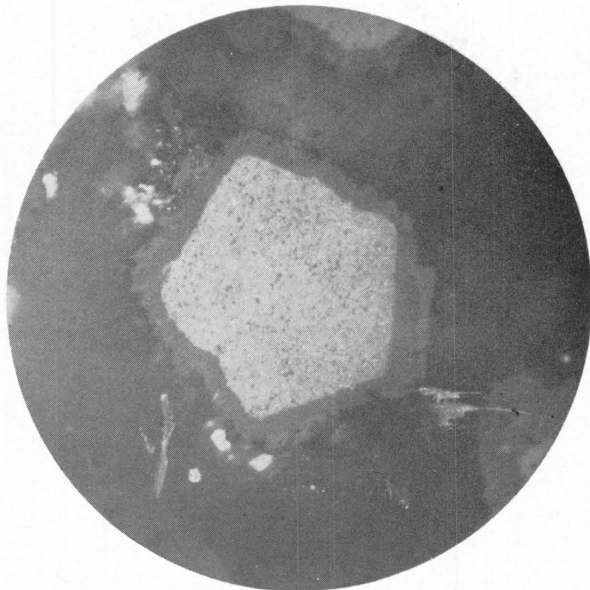

Phot. 13. Around native silver (greyish white) is seen a coating of diarsenides of Ni and Co (grey). The inner part consist of chloantite and the outer part of rammelsbergite. Crossednicolls. 300 \times . Mine Christian VII. 150 m level.

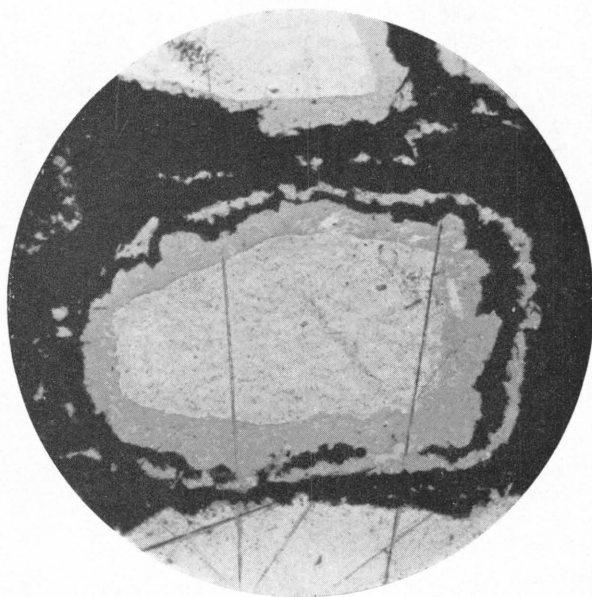

Phot. 14. Chloantite (grey) as a double coating around native silver (white, tarnished). Calcite (black). 200 \times . Mine Christian VII. 150 m level.

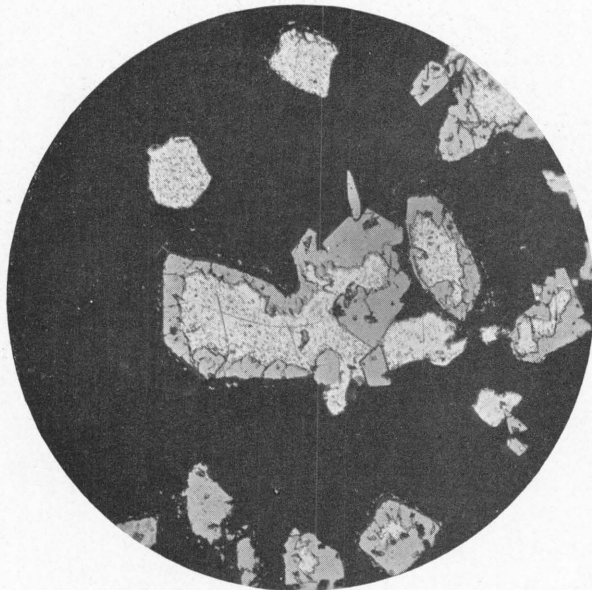

Phot. 15. Rammelsbergite (grey) in crystals which are euhedral with reference to older native silver (white, tarnished). This is a phenomenon of recrystallisation. Calcite (black). 50 \times . Mine Christian VII. 150 m level.

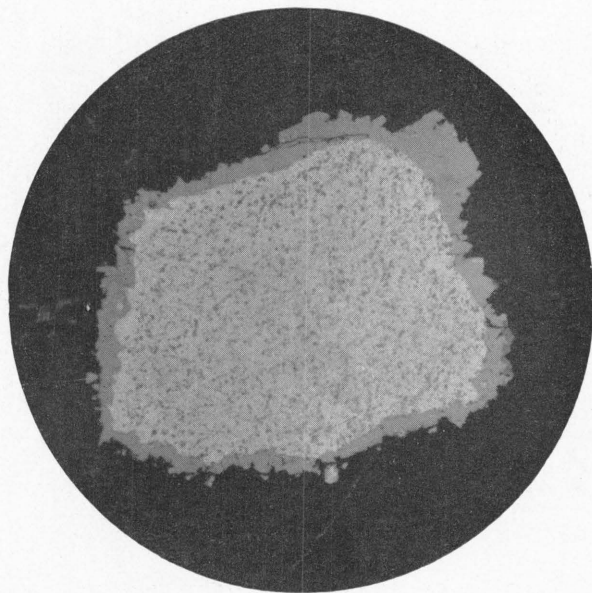

Phot. 16. Coating of rammelsbergite (grey) around a thread of native silver (white, tarnished). Calcite (black). 300 \times . Mine Cristian VII. 150 m level.

Norges Geologiske Undersøkelse

har utgitt i kommisjon hos H. Aschehoug & Co. i Oslo:

1. Årbok for 1891. Kr. 1.50.
2. *Homan*. Tekst til kartbladet Selbu. 1890. Kr. 1.00.
3. *J. H. L. Vogt*. Salten og Ranen. 1891. Utsolgt.
4. *Reusch* m. H. Det nordlige Norges geologi. Utsolgt.
5. *Stangeland*. Torvmyrer, „Sarpsborg“. 1 kart. 1892. Kr. 1.00.
6. *J. H. L. Vogt*. Dannelsen av jernmalforekomster. 1892. Utsolgt.
7. *J. H. L. Vogt*. Nikkelforekomster og nikkelproduktion. 1892. Utsolgt.
8. *Stangeland*. Torvmyrer, „Nannestad“. 1892. Kr. 1.50.
9. *Helland*. Jordbunden i Norge. 1893. Utsolgt.
10. *Helland*. Tagskiffer, heller og vekstene. 1893. Kr. 3.00.
11. *W. C. Brøgger*. Lagfølgen paa Hardangervidda. 1893. Kr. 2.50.
12. *Riiber*. Norges granitindustri. 1893. Kr. 1.00.
13. *Bjørlykke*. Tekst til kartbladet Gausdal. 1893. Kr. 1.00.
14. Årbok for 1892 og 93. 1894. (Innhold: *Reusch*, Strandflaten; *Reusch*, Mellem Bygdin og Bang. *Reusch*, Isdæmmede innsjøer. *Bjørlykke*, Høifjeldskvarts. *Friis*, Feltspat og glimmer. *Helland*, Dybder i innsjøer; *Helland*, Leraldid i Værdalen. *Ryan*, Torvprøver.) Kr. 2.50.
15. *J. H. L. Vogt*. Dunderlandsdalens jernmalmfelt. 1894. Kr. 2.00.
16. *Helland*. Jordbunden i Jærlsberg og Larviks amt. 1894. Kr. 3.00.
17. *J. H. L. Vogt*. Nissedalens jernmalforekomst. 1895. Kr. 1.25.
18. *Helland*. Jordbunden i Romsdals amt. I. 1895. Utsolgt.
19. *Helland*. Jordbunden i Romsdals amt. II. 1895. Utsolgt.
20. *Stangeland*. Om Torvmyrer i Norge. I. 1896. Kr. 1.50.
21. Årbok for 1894 og 95. 1896. (*Reusch*, Referater av geologisk litteratur vedkommende Norge 1890—95.) Kr. 2.00.
22. *J. H. L. Vogt*. Norsk marmor. 1897. Kr. 5.00.
23. *Helland*. Lofoten og Vesteraalen. 1897. Kr. 2.50.
24. *Stangeland*. Torvmyrer i Norge. II. 1897. Kr. 2.50.
25. *Bjørlykke*. Kristiania by. 1898. Kr. 2.50.
26. Norges Geologiske Undersøkelsses utstilling i Bergen 1898. Utg. av *Bjørlykke*. Kr. 0.50.
27. *Friis*. Jordboringer i Værdalen o. s. v. 1898. Kr. 1.00.
28. Årbok for 1896 til 99. (Innhold: *Hansen*, Skandinaviens stigning. *Helland*, Strandlinjernes fald. *Rekstad*, Foldalen. *Rekstad*, Forandringer hos bræer. *Dal*, Varangerfjord.) Kr. 2.00.
29. *J. H. L. Vogt*. Søndre Helgeland. 1900. Kr. 2.50.
30. *Münster*. Tekst til kartbladet Lillehammer. 1901. Kr. 1.00.
31. *W. C. Brøgger*. Om de sen-glacielle og post-glacielle nivåforandringer i Kristianiafeltet. 1900—1901. Kr. 10.00.
32. Årbok for 1900. (Innhold: 9 avhandlinger av *Reusch* om geologiske forhold i Værdalen, Stjørdalen, Valdres, Lister, ved Lysefjorden, Flekkefjord, Bergen og Trondhjem. Norges daler og fjeld. Kr. 3.00.
33. Årbok for 1901. (Innhold: *Reusch*, Referater 1896—1900.) Kr. 2.00.
34. Årbok for 1902. (Innhold: *Kiær*, Etage 5 i Asker. *Reusch*, *Rekstad* og *Bjørlykke*, Fra Hardangervidden. *Rekstad*, Bræer i Sogn og Nordfjord. *Rekstad*, Velfjorden.) Kr. 2.50.
35. *Schiøtz*, Den sydøstlige Del av Sparagmit-Kvartsfjeldet. 1902. Kr. 3.00.
36. Årbok for 1903. (Innhold: *Friis*, Andøen. *Reusch*, Det indre av Finmarken. *Kaldhol*, Suldalsfjeldene. *Rekstad*, Høifjeldsstrøket Haukeli—Hemsedal. *Rekstad*, Skoggrænsen.) Kr. 3.50.
37. Årbok for 1904. (Innhold: *Holmboe*, Skjælbanker. *Bjørlykke*, Brumunddalen. *Hansen*, Mjøsjøkelen. *Rekstad*, Kartbladet Dønna. *Kiær*, Brumunddalen. *Rekstad*, Jotunfjeldene. *Reusch*, Eggedal.) Kr. 3.50.
38. *Stangeland*. Om Torvmyrer i Norge. III. 1904. Kr. 2.50.
39. *Bjørlykke*. Det centrale Norges fjeldbygning. 1905. Kr. 10.00.
40. *Reusch*. Kartbladet Voss. 1905. Kr. 2.00.
41. *W. C. Brøgger*. Strandlinjens beliggenhet under stenalderen. 1905. Kr. 4.00.
42. *A. W. Brøgger*. Økser av Nøstvettypen. 1905. Kr. 2.00.
43. Årbok for 1905. (Innhold: *Bjørlykke*, Selsmyrene og Lesjevandene; *Bjørlykke*, Ra'erne. *J. H. L. Vogt*, Eruptivfelter. *J. H. L. Vogt*, Andøens jurafelt. *Rekstad*, Folgefossen. Indre Sogn. *C. Bugge*, Kalksten i Romsdals amt.) Kr. 3.50.
44. Årbok for 1906. (*Reusch*, Referater 1901—1905.) Kr. 2.50.
45. Årbok for 1907. (Innhold: *Rekstad*, Folgefonnaelvoen. *C. Bugge*, Bergverksdriften 1901—1905. Stenindustri. *Reusch*, Skredet i Loen 1905. *Holtedahl*, Alunskiferfeltet ved Øieren.) Kr. 3.00.
46. *J. H. L. Vogt*. De gamle norske jernværk. 1908. Kr. 1.50.
47. *Reusch*. Tekst med geol. kart Jostedalbræen—Ringerike. 1908. Kr. 2.50.
48. *Bjørlykke*. Jæderens geologi. 1908. Kr. 2.50.
49. Årbok for 1908. (Innhold: *Reusch*, Den Geologiske Undersøkelsses opgaver. *Goldschmidt*, Profilet Ringsaker—Brøttum. *Holmsen*, Børgfjeld. *Rekstad*, Fra Sondhordland (Etne m. m.). *Kaldhol*, Den nordøstlige del av Ryfylke. *Rekstad*, Kvartær, Nordmar.) Kr. 4.50.
50. *Reusch*. Norges geologi. 1910. Utsolgt.
51. *J. H. L. Vogt*. Norges Jernmalforekomster. 1910. Kr. 4.00.
- 52a. *Grimnes*. Jæderens jordbund. 1910. Kr. 1.50. 52b. *Grimnes*. Kart over Jæderen med angivelse av høideforholdene og jordbundens art. 1: 50 000. Kr. 2.50.
53. Årbok for 1909. (Innhold: *Rekstad*, Strøket mellem Sognefjord, Eksingedal og Vossestranden; *Rekstad*, Bindalen og Leka. *Werenkiold*, Øst-Telemarken. *Goldschmidt*, Tonsaasen. *Oxaal*, Børgfjeld. *Th. Vogt*, Langøen.) Kr. 4.00.
54. *Hansen*. Fra istidene. Vest-raet. 1910. Kr. 3.50.
55. *Danielsen*. Bidrag til Sørlandets kvartærgeologi. 1910. Kr. 2.00.
56. *C. Bugge*. Kartbladet Rennebu. 1910. Kr. 2.50.
57. Årbok for 1910. (Innhold: *Werenkiold*, Fra Numedal. *Hoel*, Okstinderne. *Rekstad*, Ytre del av Saltenfjord. *Reusch*, De formodede strandlinjer i Øvre Gudbrandsdalen.) Kr. 3.50.
58. *Werenkiold*. Fornebolandet og Snarøen i Østre Bærum. 1911. Kr. 2.00.
59. Årbok for 1911. (Innhold: *Oxaal*, Indre Helgeland. *Rekstad*, Hardanger. *Carstens*, Mo prestegjæld *Marstrander*, Svartisen.) Kr. 3.50.

60. *Werenskiöld*. Kartbladet Søndre Fron. 1911. Kr. 3.00.
61. Årbok for 1912. (Innhold: *Holmsen*, Hatfjeldsdalen. *Bugge*, Trondhjemsfeltet. *Rekstad*, Bjelladalen; *Rekstad*, Øerne utenfor Saltenfjord; *Rekstad*, Mytilusfauna i Smaalene. *Oxaal*, Eksport av sten 1870—1911.) Kr. 3.50.
62. *Rekstad*. Bidrag til Nordre Helgelands geologi. 1912. Kr. 3.00.
63. *Holte Dahl*. Kalkstensforekomster i Kristianiafeltet. 1912. Kr. 2.50.
64. *Reusch*. Tekst med geol. oversigtskart over Søndhordland og Ryfylke. 1913. Kr. 2.50.
65. *Bjørlykke*. Norges kvartærgeologi. En oversigt. 1913. Utsolgt.
66. *Werenskiöld*. Tekst med geol. oversigtskart Setersdalen—Ringerike. 1912. Kr. 2.50.
67. *Rekstad*. Fjeldstroket mellem Saldalen og Dunderlandsdalen. 1913. Kr. 2.50.
68. Årbok for 1913. (Innhold: *Oxaal*, Hvit granit. *Schiøtz*, Isskillet, Fæmund. *Reusch*, Tryssil. *Foslie*, Ramsøy titanmalmsfelt.) Kr. 3.00.
69. Årbok for 1914. (Innhold: *Rekstad*, Lyster og Bøverdalen. *Oxaal*, Kalkstenshuler i Ranen. *Rekstad*, Kalksten fra Nordland. *Reusch*, Hitterens og Smø lens geologi. *Holte Dahl*, Fossiler fra Smølen.) Kr. 3.00.
70. Fem avhandlinger. (Innhold: *Reusch*, Norges Geologiske Undersøkelse. *Werenskiöld*, Det sydlige Norge. *Th. Vogt*, Nordland. *J. H. L. Vogt*, Bergverksdrift. *Oxaal*, Stenindustri.) 1914. Kr. 1.00.
71. *Kolderup*. Kartbladet Egersund. 1914. Kr. 2.50.
72. *J. H. L. Vogt*. Grongruberne og Nordlandsbanen. 1915. Kr. 2.00.
73. *Holmsen*. Brædømte sjøer i Nordre Østerdalen. 1915. Kr. 4.00.
74. *Holmsen*. Tekst med geol. oversigtskart Østerdalen—Fæmundstroket. 1915. Kr. 2.50.
75. Årbok for 1915. (Innhold: *Holte Dahl*, lagtagelser over fjeldbygningen omkring Randsfjords nordende. *Holte Dahl*, Nogen foreløbige meddelelser fra en reise i Alten i Finmarken. *Rekstad*, Kvartær tidsregning. *Reusch*, Den formodede littorinansenkning i Norge. *Rekstad*, Helgelands ytre kyststrand. *J. H. L. Vogt*, Om manganrik sjømalen i Storsjøen, Nordre Odalen.) Kr. 4.00.
76. *Oxaal*. Norsk granit. 1916. Kr. 4.00.
77. *Goldschmidt*. Konglomeraterne inden høifjeldskvartsen. 1916. Kr. 2.00.
78. *Holmgreen*, Natursten. 1916. Kr. 1.50.
79. Årbok for 1916. (Innhold: *Holmsen*, Rendalens bræsjo; *Holmsen*, Sorfalden—Riksgrensens. *Rekstad*, Kyststroket mellem Bodø og Folden. *Reusch*, Litt om Jutulugget.) Kr. 3.50.
80. *Rekstad*. Vega, Beskrivelse til det geologiske generalkart. 1917. Kr. 3.00.
81. Årbok for 1917. (Innhold: *Reusch*, Seterne i Østerdalen. *Holte Dahl*, Kalkstensforekomster paa Sorlandet. *Holmsen*, Sultifjelmtrakten. *Rekstad*, Fauske—Junkerdaalen. Kr. 3.50.
82. *C. Bugge*. Kongsbergfeltets geologi. [Karter og plancher i konvolut.] 1917. Kr. 12.00.
83. Årbok for 1918 og 19. (Innhold: *Holmsen*, Gudbrandsdalens bræsjo. *Carstensen*, Geologiske undersøkelser i Trondhjems omegn. *Reusch*, Nogen kvartærgeologiske iakttagelser fra det Romsdalske) *Rekstad*, Geologiske iakttagelser fra strekningen Folla—Tysfjord. *Holmsen*, Nordfollas omgivelser. Kr. 3.50.
84. *Holte Dahl*. Bidrag til Finmarkens geologi. 1918. Kr. 4.00.
85. *J. H. L. Vogt*. Jernmalm og Jernverk. 1918. Kr. 3.50.
86. *Oxaal*. Dunderlandsdalen. 1919. Kr. 3.00.
87. Årbok for 1920 og 21. (Innhold: *Holte Dahl*, Kalksten og dolomit i de østlandske dalfører. *A. Bugge*, Nikkelgruber i Bamle. *Foslie*, Raana noritfelt. *Rekstad*, Et fund av skjælførende leir i Lørenskog. *Falck-Muus*, Brynestensindustrien i Telemarken. *Reusch*, Huler dannet ved forvitring. *Rosenlund*, Fvø gruber.) Kr. 5.00.
88. *Rekstad*, Kartbladet Eidsberg. 1921. Kr. 2.00.
89. *Holte Dahl*. Kartbladet Engerdalen. 1921. Kr. 2.50.
90. *Holmsen*. Torvmyrernes lagdeling i det sydlige Norges lavland. 1922. Kr. 6.00.
91. *Rekstad*. Kvartære avleiringer i Østfold. 1922. Kr. 1.00.
92. *Rekstad*. Grunnvatnet. 1922. Kr. 1.00.
93. *J. H. L. Vogt*. Tryktunneller og geologi. Med et avsnitt: *Fredrik Vogt*: Spændinger i fjeldet ved tryktunneller. 1922. Kr. 2.00.
94. *Gronlie*. Strandlinjer, moræner og skjælføremkomster i den sydlige del av Troms fylke. 1922. Kr. 1.00.
95. *A. Bugge*. Et forsøk paa inndeling av det syd-norske grunnfjeld. 1922. Kr. 0.75.
96. *Rekstad*. Norges heving efter istiden. 1922. Kr. 1.25.
97. *Holte Dahl* og *Schetelig*. Kartbladet Gran. 1923. Kr. 2.50.
98. Årbok for 1922. Kr. 2.00.
99. *Holmsen*. Vore myrsers plantedække og torvarter. 1923. Kr. 5.00. Innbundet kr. 6.50
100. *Rekstad*. Hans Reusch. Nekrolog og bibliografi. 1923. Kr. 1.00.
101. *Andersen*: Ildfaste oksydens fysikalske kemi. Statens Raadskomite, publ. nr. 1. 1922. Kr. 1.50. Plancher og tabeller til nr. 101 kan kjøpes særskilt in plano. Kr. 1.00.
102. *Holte Dahl* og *Andersen*: Om norske dolomiter. S. R. K. publ. nr. 2. Kr. 1.00.
103. *Andersen*: En forekomst av ren kvarts i Krødsherred. S. R. K. publ. nr. 3. Kr. 0.75.
104. *Bull*: Elektrisk metalsmelting. S. R. K. publ. nr. 4. 1922. Kr. 0.75.
105. *Lindeman*: Torv. S. R. K. publ. nr. 5. 1922. Kr. 0.75.
106. *C. Bugge* og *Foslie*: Norsk arsenmalm og arsenikkfremstilling. S. R. K. publ. nr. 6. 1922. Kr. 1.00.
107. *Goldschmidt*: Om fremstilling av bariumlegeringer. S. R. K. publ. nr. 7. Kr. 1.00.
108. *Goldschmidt* og *Johnson*: Glimmermineralernes betydning som kalikilde for planterne. S. R. K. publ. nr. 8. 1922. Kr. 2.00.
109. *Johnson*: Om tilgodegjørelsen av kalifeltspatens kalinhold. S. R. K. publ. nr. 9. 1922. Kr. 2.00.
110. *C. Bugge*: Statens apatitdrift i rationeringstiden. S. R. K. publ. nr. 10. 1922. Kr. 1.00.
111. *Gram*: Undersøkelser over bituminøse kul fra Spitsbergen. S. R. K. publ. nr. 11. 1922. Kr. 1.00.
112. *Gram*: Den kem. sammensætning av Spitsbergen—Bjørnøykul. S. R. K. publ. nr. 12. 1923. Kr. 1.00.
113. *Rødland*: Oljefremstilling av Kingsbay-kul og kul og skifer fra Andøen. S. R. K. publ. nr. 13. 1924. Kr. 1.00.
114. *Hansteen Cranner*: Om vegetationsforsøk med glimmermineralerne biotit og sericit som kalikilde. S. R. K. publ. nr. 14. 1922. Kr. 1.50.
115. *v. Krogh*: Undersøkelser over norske lerer. I. S. R. K. publ. nr. 15. 1923. Kr. 1.00.
116. *Diétrichson*: Undersøkelser over norske lerer. II. S. R. K. publ. nr. 16. 1923. Kr. 2.00.
117. *Guertler* og *Bull*. Kort oversigt over kobberets indflydelse paa jern og staa. S. R. K. Publ. nr. 17. 1923. Kr. 1.00.
118. *Bull*: Prover med en hærdeovn for kulstofstaa. S. R. K. publ. nr. 18. 1923. Kr. 1.00.
119. *v. Krogh*: Undersøkelser over norske lerer. III. S. R. K. publ. nr. 19. 1923. Kr. 1.75.
120. *Diétrichson*: Undersøkelser over norske lerer. IV. S. R. K. publ. nr. 20. 1924. Kr. 2.00.

121. *Th. Vogt*: Sulitelmafeltets geologi og petrografi. 1927. Kr. 14.00.
 122. Årbok for 1923. Kr. 2.00.
 123. *Holmsen*: Hvordan Norges jord blev til. 1924. Utsolgt.
 124. *Rekstad*: Hatfjeldalen. Beskrivelse til det geologiske generalkart. 1924. Kr. 2.00.
 125. *Rekstad*: Træna. Beskrivelse til det geologiske generalkart. 1925. Kr. 2.00
 126. *Foslie*: Syd-Norges gruber og malmforekomster. 1925. Kr. 5.00.
 127. *Foslie*: Norges svovelkisforekomster. 1926. Kr. 3.00.
 128 a. *Andersen*: Feltspat. I. 1926. Kr. 3.00.
 128 b. *Andersen* og *Barth*: Feltspat II og III, 1931. Kr. 3.00.
 129. *Aasgaard*: Gruber og skjerp i kisdraget Øvre Guldal—Tydal. 1927. Kr. 4.00.
 130. *Arne Bugge*: En forkastning i det syd-norske grunnfjell. 1928. Kr. 3.00.
 131. *Torgersen*: Sink- og blyforekomster på Helgeland. 1928. Kr. 2.00.
 132. *Holmsen*: Lerefaldene ved Kokstad, Gretnes og Braa. 1929. Kr. 1.50.
 133. Årbok for femårsperioden 1924—1928. (Innhold: Direktørens og statsgeologenes beretning om arbeidet. *Falck-Muus*: Femårsberetning fra bibliotekaren. *C. Bugge*: Meddelelser om geologiske undersøkelser i Hallingdal og Valdres. *Falck-Muus*: Norske bergverksarkivalia II. *A. Bugge*: Oversikt over inndelingen av det sydnorske grunnfjell samt om fahlbåndene i Kongsberg ertsdistrikt. 1929. Kr. 3.00.
 134. *Rekstad*: Salta. Beskrivelse til det geologiske generalkart. 1929. Kr. 3.00.
 135. *Holmsen*: Grundvandet i vore leravsetninger. 1930. Kr. 3.00.
 136. *Holmsen*: Rana. Beskrivelse til det geologiske generalkart 1932. Kr. 4.00.
 137. *Foslie* og *Johnson Høst*: Platina i sulfidisk nikkelmalm. 1932. Kr. 2.50.
 138. *Brøgger*: Essexitrekkenes erupsjoner, den eldste vulkanske virksomhet i Oslofeltet. 1933. Kr. 3.00.
 139. *Brøgger*: Om rombeoporfyrgangene og de dem ledsagende forkastninger i Oslofeltet. 1933. Kr. 1.50.
 140. *Holmsen*: Lerfall i årene 1930—1932. 1934. Kr. 1.50.
 141. *Olaf Anton Broch*: Feltspat. IV. 1934. Kr. 3.00.
 142. *Torgersen*: Sink- og blyforekomster i det nordlige Norge. 1935. Kr. 2.00.
 143. *Arne Bugge*: Flesberg og Eiker. Beskrivelse til de geologiske gradavdelingskarter F. 35 Ø og F. 35 V. De løse avleiringer ved *A. Samuelsen*. 1937. Kr. 4.00.
 144. *Holmsen*: Nordre Femund. Beskrivelse til det geologiske rektangelkart. 1935. Kr. 2.50.
 145. *Wolmer Marlow*: Foldal. Beskrivelse til det geologiske rektangelkart. 1935. Kr. 4.00.
 146. *Arne Bugge*: Kongsberg-Bambleformasjonen. 1936. Kr. 3.00.
 147. *Falck-Muus*: Aursund (under utarbeidelse).
 148. *Holmsen*: Søndre Femund. Beskrivelse til det geologiske rektangelkart. 1937. Kr. 2.50.
 149. *Foslie*: Tysfjords geologi. Beskrivelse til det geologiske gradteigskart Tysfjord. 1941. Kr. 12.00.
 150. *Foslie*: Hellemobotn og Linnajavrre. 1942. Kr. 6.00.
 151. *Holmsen*: Våre leravsetninger som byggegrunn. 1938. Kr. 3.00
 152. *Trygve Strand*: Nordre Etnedal. Beskrivelse til det geologiske gradteigskart. 1938. Kr. 3.00.
 153. *Carl Bugge*: Hemsedal og Gol. Beskrivelse til de geologiske gradteigskarter E 32 V og E 32 Ø. 1939. Kr. 4.00.
 154. *Harald Bjørlykke*: Feltspat V. De sjeldne mineraler på de norske granittiske pegmatittganger. 1939. Kr. 3.00.
 155. *Olaf Anton Broch*, *Fridtjov Isachsen*, *Orvar Isberg*, *Trygve Strand*: Bidrag til Skudenes-sedimentenes geologi. 1940. Kr. 1,50.
 156. *K. O. Bjørlykke*: Utsyn over Norges jord og jordsmønn. Med oversiktskarter av jordbunnsforholdene i Norge i to blader: Sør-Norge og Nord-Norge. 1:2 000 000. 1940. Kr. 8.00.
 157. *Brit Hofseth*: Geologiske undersøkelser ved Kragerø, i Holleia og Troms. 1942. Kr. 3.00.
 158. *Per Holmsen*: Geologiske og petrografiske undersøkelser i området Tynset—Femunden. 1943. Kr. 2.50.
 159. *Trygve Strand*: Et gneis-amfibolittkompleks i grunnfjellet i Valdres. 1943. Kr. 3,00.
 160. *Jens A. W. Bugge*: Geological and Petrographical Investigations in the Kongsberg—Bamble Formation. 1943. Kr. 5.00
 161. *Christoffer Ofte Dahl*: Om Sparagmiten og dens skyvning innen kartbladet Øvre Rendal. 1943. Kr. 2.50.
 162. *H. Neumann*: Silver Deposits at Kongsberg. 1944. Kr. 4,50.

Statens Råstoffkomité's publikasjoner.

Av Statens Råstoffkomité's publikasjoner er utkommet nr. 1—26, hvorav nr. 1—20 er utgitt i ovennevnte serie som N. G. U. nr. 101—120. Nr. 21, 22, 24 og 26 fåes i *Teknisk Ukeblads ekspedisjon*, Oslo.

Smaaskrifter.

Av denne serie, er utkommet:

- Nr. 1. *Andersen*: Norges Geologiske Undersøkelse, dens oppgaver og virksomhet. 1922. Gratis.
 2. *Falck-Muus*: Avhandlinger og karter utgitt av N. G. U., systematisk ordnet. 1922. Gratis.
 3. *Holmsen*: Erfaringer om jordskaden ved innsjøreguleringer. 1927. Kr. 0.50.
 4. *Holmsen*: Grunnvannbrønner. 1940. Kr. 0.50.

Karter

Følgende farvetrykte geologiske karter er til salgs ved Norges Geografiske Opmåling:

Rektangel- og gradavdelingskarter, kr. 1.00: Dunderlandsdalen, Eidsberg, Gausdal, Gjøvik, Gran, Hamar, Haus, Hønefoss, Kongsberg, Kristiania, Lillehammer, Melhus, Meraker, Moss, Rennebu, Sarpsborg, Selbu, Skjønn, Søndre Fron, Terningen, Tysfjord, Tønsberg med Larvik, Voss, Flesberg, Eiker, Foldal, Nordre Femund, Aursund, Søndre Femund, Hellemobotn, Linnajavrre, Nordre Etnedal, Hemsedal, Gol.

Utsolgt: Amot, Nannestad, Eidsvoll, Bergen, Rindal, Stenkjær, Levanger, Stjørdal, Trondhjem. *Av Oslofeltets serie er utkommet*: Gran, Hønefoss, Nannestad, Flesberg, Kristiania, Fet, Kongsberg, Moss, Tønsberg med Larvik, samt oversiktskart.

Forskjellige geologiske karter: Generalkartene: Hatfjeldal, Rana, Salta, Træna, Vega (kr. 2.00). Oversiktskart over det sydlige Norge (utsolgt) og oversiktskart over det nordlige Norge. (kr. 3.00).